



Model 5015
Dual Monitoring Converter
Serial Digital 4:2:2 to
Analog Composite Video
and Reclocked SDV

Owner's Manual

5015 Owner's Manual

The Cobalt Digital 5015 is a Leitch™ Digital Frame compatible card that provides two independent 4:2:2 serial digital video to analog composite conversions and reclocked serial digital video.

The 5015 allows the end user to select the analog or digital output configuration as need for a given application (Fig. 1). The board has two, A and B, SDV conversion encoders. The A encoder has four outputs, of which two are fixed analog composite and two can be configured as SDV or analog composite. The B converter has three outputs. One is fixed analog and the other two can be configured as reclocked SDV or analog composite video.

Output gain control for analog composite is adjustable from the card edge as well as configuration switches for both converters. Gain level can be set +/- 10 IRE.

Configuration settings are Setup on/off, Color Bars on/off (color bar mode requires and active SDV input to be present to clock the output composite encoder), Auto NTSC/PAL detect and self configure on/off, manual selection of NTSC or PAL output and Color on/off (off for better performance on a monochrome monitor).

A unique feature of the 5015 is conversion density. A Leitch™ two rack unit Digital Frame completely filled with 10 cards, yields 20 conversions per frame. The total power consumption for 10 cards is below 70 Watts which allows the frame to operate with one power supply.

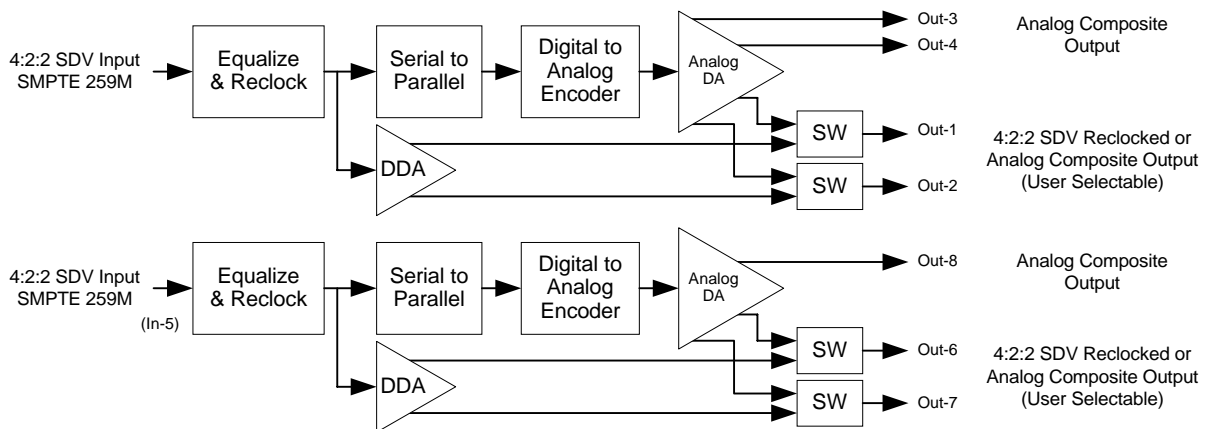

Fig. 1: 5015 DUAL SDV to Analog Composite and SDV Reclocking Distribution Amplifier

5015 Owner's Manual

The Leitch™ frame provides a total of 9 BNC connectors per card. I/O configuration is shown below:

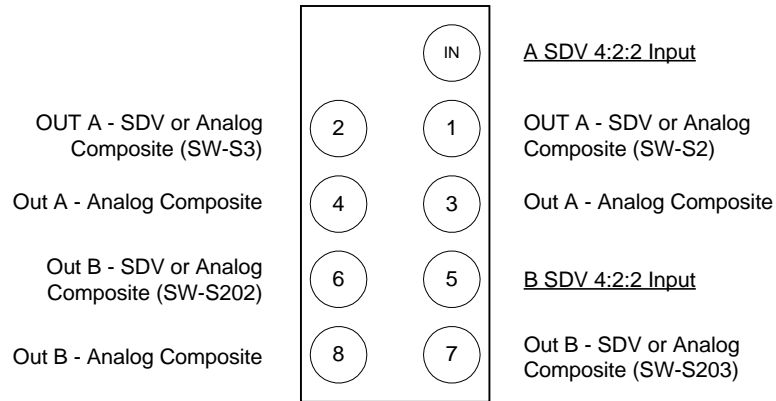

Fig. 2: Rear view of Frame BNC connector panel.

Selection of Reclocked 4:2:2 SDV or Analog Composite Output

The "A" or upper converter provides dedicated composite output on BNC connectors 3 and 4. Outputs 1 and 2 are selectable to provide a copy of the SDV received by converter "A" or an analog composite output. This selection is performed by switching the appropriate two segment dip switch located near the rear of the PCB. Likewise, Converter "B" provides switchable SDV or composite for outputs 6 and 7.

Each of the dip switches used to select either SDV or composite are set up as follows:

Output Switch Configuration

Desired output	Segment	
	1	2
SDV copy out	ON	OFF
Composite out	OFF	ON

Output Switch Identification

Dip Switch	SDV/Comp
S2	Out 1
S3	Out 2
S202	Out 6
S203	Out 7

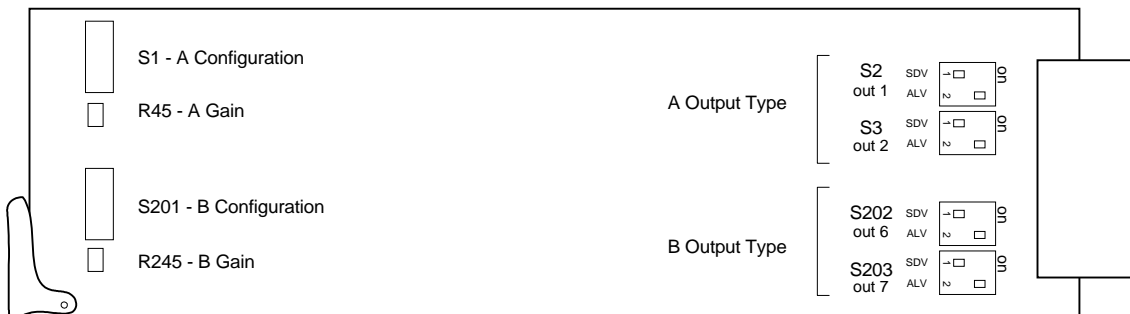

Fig. 3: 5015 Output Switch Configuration

5015 Owner's Manual

Configuration Dip Switch Settings

Each converter provides the user with two 8 segment dip switches mounted on the forward edge of the PCB (one for each converter). These switches provide the capability to set the 5015 converter to display a color bar test pattern, automatically switch between PAL and NTSC, turn setup on or off, and turn the chroma on or off. The switches work identically for each converter and function as follows (Fig. 5).

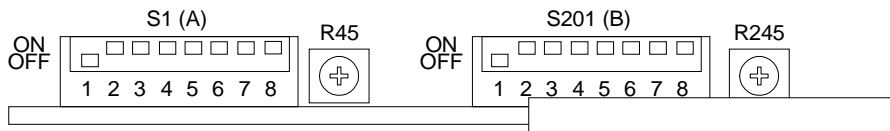

Fig. 4: Configuration Switches and Output Gain Control

Segment	Function
1	ON - Turns on Color Bar test pattern (requires valid SDV input)
2 - 4	Reserved
5	ON - Selects automatic PAL / NTSC mode, OFF = manual selection per switch 6
6	Selects NTSC (ON) or PAL (OFF) when switch 5 is in the OFF (manual) position
7	Turns setup ON or OFF (valid when in NTSC only)
8	ON - turns Chroma on, OFF - no Chroma

Note: ON is defined as the "UP" position furthest away from the bottom of the unit.

Fig. 5: Configuration Settings

Output Analog Video Gain Adjustment

To adjust the output amplitude of the analog composite output, use the potentiometers located on the front of the card next to the 8 position configuration switches (Fig. 4). Each converter has one adjustment potentiometer labeled "A GAIN" (R45) for the "A" converter and "B GAIN" (R245) for the "B" converter. Turning the adjustment clockwise increases the output amplitude, while counter-clockwise rotation reduces the output amplitude.

5015 Owner's Manual

Specifications:

Input: 525 or 625 SMPTE 259-C 4:2:2 Serial Digital Video
Equalization Auto to 1000' Belden 1694 (typical)
Return Loss >15 dB at 270 Mbit

Digital Output:
Number of Outputs 2 on A converter and 2 on B converter (switchable with composite analog)
Level 800 mV +/- 10%
Return Loss >15 dB at 270 Mbit
Reclocking Yes
Delay 10 nS

Analog Output:
Number of outputs 4 or 2 on A converter and 3 or 1 on B converter
Format Composite video following input line standard
Line Standard Auto-detecting 525/625
Video Level 100 IRE +/- 10 IRE (user adjustable)
Sync - 300 mV +/- 10%
Frequency Response 0-5 mHz +/- 0.5 dB
K-Factor <1.5%
Differential Gain <1%
Differential Phase <1%
Noise <70 dB
Chroma Luma Delay <2 nSec
SCH Phase <2 degrees
Quantizing 8 bit input converted internally to drive 10 bit DACs
Setup User selectable on/off for NTSC (Fixed off for PAL)
Return Loss >35 dB at 5 MHz

Power:
Positive Rail 6.5 Watts
Negative Rail 0.5 Watts

Temperature range: 40-110 degrees F. ambient (non-condensing)

Indicators: Two data lock indicators (one for each converter)

Notes: Specifications subject to change without notice. This product is not authorized for use in life support systems. Product liability limited only to the replacement of this unit. Cobalt Digital Inc. does not assume any liability for loss of use due to failure of this component.



Cobalt Digital Inc.

2406 E. University Ave.
Urbana, IL 61802

Ofc: 217 344-1243
Fax: 217 344-1245

sales@cobaltdigital.com
www.cobaltdigital.com