



Model HD-8024

HD/SD Up/Down/Cross

Format Converter

Owner's Manual

Table of Contents

Overview.....	4
Rear Panel.....	4
Block Diagram	5
Signal Flow	5
Conversion Capabilities.....	6
Operation.....	7
Front Panel	7
Menu	7
LCD Control	12
Lockout Front Panel	12
Preset Menu.....	12
Main Menu	13
SD Input Convert to	13
HD Input Convert to	14
Special Mode	14
HD/SD Input Aspect.....	16
User Aspect Settings.....	16
HD/SD Input Underscan	16
Output Configuration.....	16
Digital Output	17
SD Analog Output	17
SD Color.....	18
Analog NTSC Setup	18
Analog Setup Per Line	18
Test Pattern.....	18
Dual Rate	18
Oversample.....	19
HD Analog Output	19
HD Analog Sync Type	19
Reticule Controls	19
Reticule Settings	20
User Reticule Settings	20
Reticule Color.....	20
User Reticule Color.....	20
Reticule Tracking.....	21
Options	21
Video Y Gain	21
Video Saturation.....	21
Video Hue	21
Background Color.....	22
User Background Color.....	22
Encoder Oversample.....	22

HD/SD VBI	22
Motion Coprocessor	22
Auto Motion Detect.....	23
Dejitter Filter	23
Auto Color Matrix.....	23
Audio Delay Offset	23
Audio & Video Delay	23
Utilities	24
Power & Temperature	24
Remote Control	25
Unit Address.....	25
Clear All Presets.....	25
Factory Defaults	25
Versions	26
Self Tests	26
LCD Menu Timeout	26
Remote Control	26
GPIO	27
Specifications	31

Overview

The HD8024 is a high quality 10-bit, Up, Down and Cross Format converter, that bridges SMPTE 292 high definition (HD) and 259M-C standard definition (SD) signal formats.

The HD8024 provides a new user-friendly control to our popular HD8022 Format Converter. The HD8024 adds a front panel interface with LCD display and front panel switches to the HD8022 Format Converter. All video and audio features that were in the HD8022 are available within the HD8024, but now enclosed in a 1/2 rack width, 1U chassis.

The 8024 can upconvert SD, downconvert HD and cross convert from one HD standard into another and output HD/SD serial digital, HD analog and SD analog video. In addition, the 8024 can re-aspect the image in all conversion modes; change interlaced to progressive, progressive to interlaced and add 3:2 pull-down. The 8024 has user configurable reticules with defaults for center cross, 4x3 safe area, 4x3 full aperture and 16x9 safe area. The reticules can be enabled on any or all outputs. Embedded audio with corrective time delay is supported with user offsets that can be applied to correct system level audio delay errors.

The image processing is 10-bit using a 24-tap spatial filter and advanced deinterlacing with motion compensation. Down conversions of HD to SD signals are de-jittered to reduce chroma phase jitter of SD analog signals. All analog outputs are encoded at 12-bits to preserve the 10-bit video signal.

When performing up conversion, the 8024 uses multi-direction adaptive filtering for edge processing, an adaptive vertical motion filter and adaptive inter-field motion filter.

Rear Panel

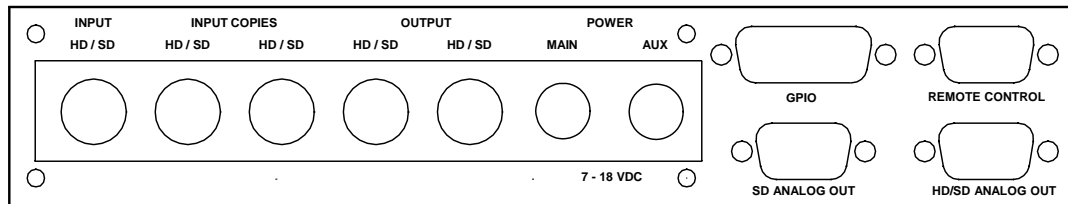

The rear panel of the 8024 includes the following connections:

- One dual-rate HD/SD serial digital input.
- Two relocked dual-rate serial digital outputs.
- Two imaged processed dual-rate serial digital outputs.
- Main and Auxiliary Power inputs.
- GPIO General Purpose Input/Output.
- RS-232 Remote Control
- SD analog output.
- Dual-rate HD/SD analog output.

Connect the HD/SD SDI input signal to the dual-rate HD/SD Input BNC connector.

Connect 7-18 VDC power to the Main Power connector. Redundant power input is available using the Aux Power connector. Either input will power the unit should the other power supply fail. Messages can alert the user to a failed supply. See Power & Temperature for more information.

The HD analog output can be YPbPr or GBR with embedded tri-level, bi-level or separate H&V sync. The SD analog output can be three composites, one composite and one Y/C, component in YPbPr (BetaCam™, MII™ or SMPTE levels) or GBR with embedded bi-level sync. Both analog video outputs are encoded to 12-bits and supplied through HD-15 (XGA) connectors.

Block Diagram

The 8024 has a very flexible signal flow path and feature set that combines several products into one compact package. To understand the capabilities of the 8024, this section reviews the basic structure of the 8024.

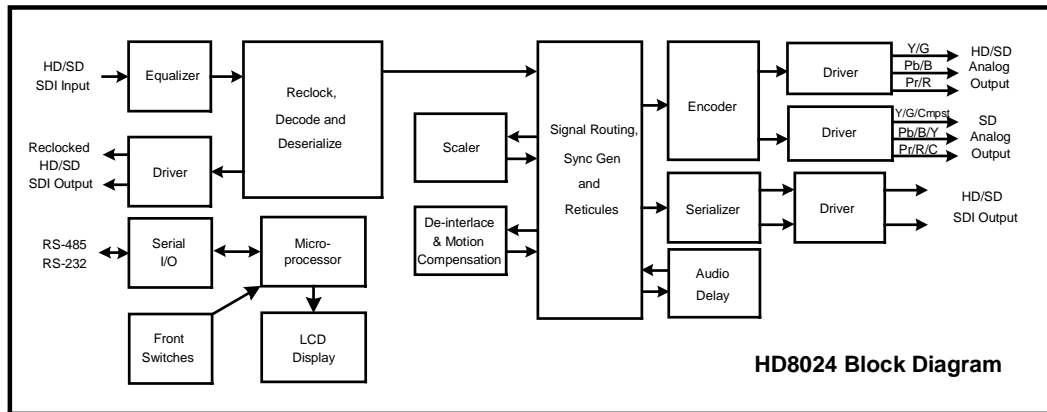

Signal Flow

Starting in the upper left of the block diagram, the dual-rate serial digital signal (HD/SD SDI) is equalized, reclocked, decoded and then deserialized. During this process, the video standard and frame rate are determined.

A copy of the reclocked serial digital signal is sent to a distribution amplifier to create two active, reclocked output loops. Each of these outputs is dual-rate and follows the input signal.

Coming out of the deserializer, the video data goes to a block that combines several functions, signal routing, sync generation and reticules. Depending on the mode of operation the signal is directed to the deinterlacer and motion compensator, the scalar for up, down, format, aspect and/or frame rate conversion, the audio delay and then the output. This block also selects which input goes to which output (HD Analog, SD Analog or SDI) and what reticules are to be applied to what outputs. Audio at the input is removed, time delayed, then reinserted into the output path.

Based on the user settings and the type of signal detected, the unit is automatically configured and the signal is sent to the correct output device to the right of the routing block. Either the converted signal or the raw signal is sent to the encoder or the serializer.

For example, an SD input may be converted to an HD signal to feed an HD monitor. While an HD input may be kept as HD, to feed the same HD monitor.

In comparison, an HD input may be converted to an SD signal to feed an SD monitor. While an SD input may be kept as SD, to feed the same SD monitor. Or, the user may select different output formats for the different SD and HD inputs.

Separate Aspect Ratios may be selected for the SD or HD inputs, allowing the user to maintain the correct output, regardless of input.

Reticules may be individually enabled for the HD Analog, SD Analog and SDI outputs.

All of the user settings are automatically saved, then recalled again at power up to return the unit to the same state of operation. Presets may also be used to save an entire set of user settings, then a different Preset may be recalled at any time to configure the unit for another application.

Conversion Capabilities

The 8024 has extensive re-format and up/down conversion capabilities. It can act as an upconverter, downconverter, cross (1080-720) converter, aspect ratio converter and frame rate converter.

The format conversion capabilities are listed in the chart below.

Input	Output						
	HD 1920x1080		HD 1280x720		XGA 1024x768	SD	
1080 sF 23.98	i 29.97	sF/p 23.98	----	p 59.94	p 59.94	486 i 29.97	
1080 p 23.98	i 29.97	p/sF 23.98	----	p 59.94	p 59.94	486 i 29.97	
1080 sF 24	i 30	p 24	----	p 60	p 60	----	
1080 p 24	i 30	sF 24	----	p 60	p 60	----	
1080 i 25	i 25	p 25	p 25	p 50	p 50	575 i 25	
1080 p 25	i 25	p 25	p 25	p 50	p 50	575 i 25	
1080 i 29.97	i 29.97	p 29.97	p 29.97	p 59.94	p 59.94	486 i 29.97	
1080 p 29.97	i 29.97	p 29.97	p 29.97	p 59.94	p 59.94	486 i 29.97	
1080 i 30	i 30	p 30	p 30	p 60	p 60	----	
1080 p 30	i 30	p 30	p 30	p 60	p 60	----	
720 p 25	i 25	p 25	p 25	p 50	p 50	575 i 25	
720 p 29.97	i 29.97	p 29.97	p 29.97	p 59.94	p 59.94	486 i 29.97	
720 p 30	i 30	p 30	p 30	p 60	p 60	----	
720 p 50	i 25	p 25	p 25	p 50	p 50	575 i 25	
720 p 59.94	i 29.97	p 29.97	p 29.97	p 59.94	p 59.94	486 i 29.97	
720 p 60	i 30	p 30	p 30	p 60	p 60	----	
486 i 29.97	i 29.97	p 29.97	p 29.97	p 59.94	p 59.94	486 i 29.97	
575 i 25	i 25	p 25	p 25	p50	p 50	575 i 25	

Notes:

1. All rates are listed as frame rates. Interlaced rates are two times the number shown. For example, i 29.97 is 29.97 frames per second or 59.94 fields per second. Progressive p 29.97 is 29.97 frames per second.
2. SD active line rates are PAL (575) and NTSC (486).

- The 8024 cannot accept native 720 p24/23.98 or sF24/23.98, however it can convert those signals if they are delivered inside a 59.94/60 transportation wrapper (as typically done with this format) and processed as 59.94/60.

Operation

All controls of the 8024 are accessed using front panel switches with status information provided on an LCD display. All controls that were previously performed using DIP and rotary switches within the 8022 are now controlled using this new front panel interface on the 8024.

Front Panel

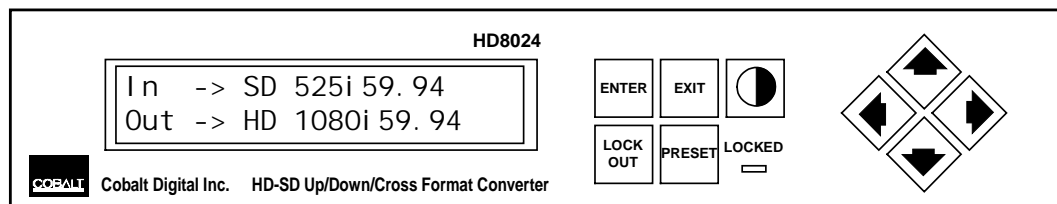

The 8024 has an LCD Display to provide status information about the current mode of operation and front panel switches used to control the unit using the menu.

When the menu is not being access to control the unit, the LCD displays the Main Screen with the following information: Input format, Output format, if no input signal is detected or if any alarm conditions exist. Listed below are some example Main Screens:

In -> HD 1080i59.94
 Out-> SD 525i59.94

No input signal
 detected.

Warning! Main Power
 Supply is too high!

Menu

The table below shows an overview of the 8024 menu structure.

Menu

Main Menu
SD Input Convert to
SD Input Aspect
SD Input Underscan
HD Input Convert to
HD Input Aspect
HD Input Underscan
Special Mode
Output Configuration
Reticule Controls
Options
Utilities

SD Input Convert to
Re-aspect to SD
720p 50/59.94
1080i 50/59.94
XGA 768p 50/59.94

SD Input Aspect
No Changes
0.75 V (Letter Box)
1.33 V
0.75 H (Pillar Box)
1.33 H (Center Cut)
User Settings

User Aspect Settings
Combined H&V Zoom
Separate H&V Zoom
Pan

LCD Control
LCD Contrast
LCD Backlight

SD Input Underscan
[No] Yes

HD Input Convert to
Re-aspect to HD
Cross 720 <-> 1080
525i 59.94 / 625i 50
720p 50/59.94/60
1080i 50/59.94/60
XGA 768p 50/59.94/60

Lockout Front Panel
[No] Yes

Preset Menu
Recall Preset
Save as Preset
Rename Preset

HD Input Aspect
No Changes
0.75 V (Letter Box)
1.33 V
0.75 H (Pillar Box)
1.33 H (Center Cut)
User Settings

User Aspect Settings
Combined H&V Zoom
Separate H&V Zoom
Pan

HD Input Underscan
[No] Yes

Special Mode
A: Standard
B: I to P
C: P to I
D: P to I +3:2pd

Output Configuration
Digital Output
SD Analog Output
SD Color
Analog NTSC Setup
Analog Setup Per Line
Test Pattern
Dual Rate
Oversample
HD Analog Output
HD Analog Sync Type

Digital Output
Follow Scaling
Always SD
Always HD
Reclocked Input

SD Analog Output
All Composite
Composite & Y/C
YPbPr BetaCam™
YPbPr MII™
YPbPr SMPTE
GBR

SD Color
[Off] On

Analog NTSC Setup
[Off] On

Analog Setup Per Line
Odd Field - Line 10 - 25
Even Field - Line 10 - 25

Test Pattern
[Off] On

Dual Rate
[HD Only] HD & SD

Oversample
[16x SD] 2x HD

HD Analog Output
[GBR] YPbPr

HD Analog Sync Type
H&V
Video Bi-level
Video Tri-level

Reticule Controls
Digital Reticules
SD Analog Reticules
HD Analog Reticules
Center Cross (+)*
4x3 Safe Area*
4x3 Full Aperture*
16x9 Safe Area*
Reticule Color
Reticule Tracking

* Reticule Settings
Off
On
User

User Reticule Settings
Size
Thickness

Reticule Tracking
[Stay Put] Track

Reticule Color
Black
Blue
Red
Magenta
Green
Cyan
Yellow
White
Gray 1
Gray 2
Gray 3
User

User Reticule Color
Gain
Saturation
Hue

Options
Video Y Gain
Video Saturation
Video Hue
Background Color
Encoder Oversample
SD VBI
HD VBI
Motion Coprocessor
Auto Motion Detect
Dejitter Filter
Auto Color Matrix
Audio Delay Offset
Audio & Video Delay

Video Y Gain
100 IRE

Video Saturation
100 IRE

Video Hue
0.00°

Encoder Oversample
[No] Yes

SD VBI
[No] Yes

HD VBI
[No] Yes

Motion Coprocessor
[No] Yes

Auto Motion Detect
[No] Yes

Dejitter Filter
[No] Yes

Auto Color Matrix
[No] Yes

Background Color
Black
Blue
Red
Magenta
Green
Cyan
Yellow
White
Gray 1
Gray 2
Gray 3
User

User Background Color
Gain
Saturation
Hue

Audio Delay Offset
-100 to 1000 milliseconds

Audio & Video Delay
Audio Delay in ms
Video Delay in ms

Utilities
Power & Temperature
Remote Control
Unit Address
Clear All Presets
Factory Defaults
Versions
Self Tests
LCD Menu Timeout

Power & Temperature
Main Power Supply
Aux Power Supply
Front Panel Temperature
Front Panel Maximum
Scaler Temperature
Scaler Maximum
Main Power Alarm
Aux Power Alarm
Temperature Alarm

Versions
Scaler PIC
Scaler FPGA
Scaler EPLD
Scaler Bootloader
Scaler Filter
Scaler Unit Type
Front Panel PIC
Front Panel Bootloader

Remote Control
Off [Active] Passive

Unit Address
0 – 255

Clear All Presets
[No] Yes

Factory Defaults
[No] Yes

Self Tests
All Tests
Power Test
Temperature Test
EEPROM Test
LCD Test
Button Test
LED Test
RS-232 Test

LCD Menu Timeout
Off, 3 – 250 Seconds

Menu Operation

Press ENTER to access the Main Menu. Press UP or DOWN to select an item. Then press LEFT or RIGHT to adjust that item. Some menus require pressing ENTER to access a subset of controls available. While traversing the menu system, you can always repeatedly press EXIT to return to the Main Screen.

All numerically adjusted items may be returned to their default values by pressing both buttons used to adjust that item; i.e., while adjusting Vertical Pan, press both UP and DOWN to return Vertical Pan to its default value. While adjusting Video Hue, press both LEFT and RIGHT to return Video Hue to its default value.

Each menu is described with further details below.

LCD Control
LCD Contrast
LCD Backlight

The LCD Control menu provides contrast and backlight control of the LCD display. Press the CONTRAST/JUMP button to access the LCD Control menu. Press UP or DOWN to select Contrast or Backlight, then press LEFT or RIGHT to change the setting. Changes are stored in memory and will remain in effect until changed again or a factory reset is performed.

Note: The LCD Control menu is only available from the Main Screen. The CONTRAST/JUMP button performs other functions elsewhere within the menu.

Lockout Front Panel
[No] Yes

The Lockout Front Panel prevents unwanted or accidental changes to the unit. Press LOCKOUT, then select Yes to lockout the front panel. This disables all front panel buttons except LOCKOUT. Press LOCKOUT again and select No to enable the front panel. Normal RS-232 control is always available regardless of this setting.

Preset Menu
Recall Preset
Save as Preset
Rename Preset

The Preset menu provides unique control of the 8024. When Presets are used, all settings are stored in the selected Preset, then may be recalled again at a later time.

To Recall a Preset, press PRESET to access the Preset menu. The Recall Preset menu will appear. Press LEFT or RIGHT to select the desired Preset to recall. Press ENTER to recall the Preset. The LCD will confirm the action. The unit will now operate using the new Preset, just as if all of the settings were adjusted using the standard menu controls.

To Save a Preset, first adjust all settings to the unit as desired using the standard menu controls. Once the settings are ready to be saved, press PRESET to access the Preset menu. Press UP or DOWN to access the Save as Preset menu. Press LEFT or RIGHT to

select the desired Preset to save to. Press ENTER to save the Preset. The LCD will confirm the action. Any old information for the selected Preset will be overwritten.

To Rename a Preset, press PRESET to access the Preset menu. Press UP or DOWN to access the Rename Preset menu. Press LEFT or RIGHT to select the desired Preset to rename. Press ENTER to begin renaming the Preset. Press LEFT or RIGHT to select the character to edit and press UP or DOWN to edit that character. Press ENTER or EXIT to save the new name for that Preset.

To copy a Preset, first recall the desired Preset to copy from, then save to desired Preset.

To clear an individual Preset, first perform a Factory Default, then Save the current settings to the desired Preset. Note: Performing a Factory Default does not clear any Presets, it only resets the current mode of operation.

To clear all Presets, use the menu: Utilities -> Clear All Presets.
Note: This will also reset the current operation of the unit.

If new Preset settings will closely match an already-saved Preset, simply recall that Preset first, then change settings as desired, then save this new Preset in a different location.

If Presets are not used, the unit still functions normally and always remains in the same state, even when powered-down and powered-up, until further changes are made using the standard menu controls.

Main Menu
SD Input Convert to
SD Input Aspect
SD Input Underscan
HD Input Convert to
HD Input Aspect
HD Input Underscan
Special Mode
Output Configuration*
Reticule Controls*
Options*
Utilities*

Press ENTER to access the Main Menu. Press UP or DOWN to select an item. Then press LEFT or RIGHT to adjust that item. Press ENTER to access a submenu for those items with an asterisk (*).

SD Input Convert to
Re-aspect to SD
720p 50/59.94
1080i 50/59.94
XGA 768p 50/59.94

The SD Input Conversion menu selects the type of conversion to perform when an SD signal is present. Four types of SD input conversions are available: Re-aspect to SD, Upconvert to 720p, Upconvert to 1080i, or Upconvert to XGA (1024x768p). Selecting a

new value will flash on the LCD display. Press ENTER to confirm the change, or press EXIT to abort.

HD Input Convert to
Re-aspect to HD
Cross 720 <-> 1080
525i 59.94 / 625i 50
720p 50/59.94/60
1080i 50/59.94/60
XGA 768p 50/59.94/60

The HD Input Conversion menu selects the type of conversion to perform when an HD signal is present. Six types of HD input conversions are available: Re-aspect to HD, Cross-convert 720p to/from 1080i, Downconvert to 525i/625i, Convert to 720p, Convert to 1080i, or Convert to XGA (1024x768p). Selecting a new value will flash on the LCD display. Press ENTER to confirm the change, or press EXIT to abort.

Special Mode
A: Standard
B: I to P
C: P to I
D: P to I +3:2

The Special Mode menu is used to control the unit's operation when any of the special conversion modes are desired. Selecting a new value will flash on the LCD display. Press ENTER to confirm the change, or press EXIT to abort.

Select Special Mode A: Standard (default) to correctly process the following standard input and output formats:

1920x1080 i25/29.97/30,
1280x720 p50/59.94/60,
1024x768 p50/59.94/60,
720x625 i25,
720x525 i29.97.

If any of the following formats are used as input or output, then refer to the table below to select the Special Mode required for the desired mode of operation.

1920x1080 p25/29.97/30, sF23.98/24, p23.98/24,
1280x720 p25/29.97/30.

Special Mode Table

		Serial Digital or Analog Output																				
		1920 x 1080i										1280 x 720					1024 x 768 Analog only			720x625	720x525	
		i 30	i 29.97	i 25	p 30	p 29.97	p 25	sF 24	sF 23.98	p 24	p 23.98	p 60	p 59.59	p 50	p 30	p 29.97	p 25	p 60	p 59.95	p 50	i 25	i 29.97
Serial Digital Input	1920 x 1080	i 30	A		B						A		B			A						
		i 29.97		A		B						A		B				A				A
		i 25			A		B						A		B				A	A		
		p 30	C		A						C		A			C						
		p 29.97		C		A						C		A			C					C
		p 25			C		A						C		A				C	C		
		sF 24	D					C		B		D					D					
		sF 23.98		D					C	B			D					D				D
		p 24	D					C		A		D						D				
	p 23.98		D					C		A		D						D				D
	1280 x 720	p 60	A			B					A		B			A						
		p 59.59		A		B						A		B			A					A
		p 50			A		B						A		B			A	A			
		p 30	C		A						C		A			C						
		p 29.97		C		A						C		A			C					C
		p 25			C		A						C		A				C	C		
	720x 625	i 25		A		B							A		B			A	A			
	720x 525	i 29.97		A		B						A		B			A					A

Special Modes

- A: Standard Conversions
- B: Interlaced to Progressive
- C: Progressive to Interlaced
- D: Progressive to Interlaced +3:2 Pulldown

HD/SD Input Aspect
No Changes
0.75 V (Letter Box)
1.33 V
0.75 H (Pillar Box)
1.33 H (Center Cut)
User Settings

The Input Aspect menu selects the aspect ratio conversion desired. Six Aspect Ratios are available: No Changes, 0.75V (Letter Box), 1.33V, 0.75H (Pillar Box), 1.33H (Center Cut) and User Settings with custom Zoom and Pan controls. Two sets of menus are available, one for HD inputs and another for SD inputs.

User Aspect Settings
Combined H&V Zoom
Separate H&V Zoom
Pan

Once User Settings is reached within the SD/HD Input Aspect Menu, press ENTER to access the User Aspect Settings submenu. Press LEFT or RIGHT to select between Combined H&V Zoom, Separate H&V Zoom and Pan. Combined H&V Zoom adjusts both Horizontal and Vertical Zoom simultaneously. Separate H&V Zoom allows separate Horizontal and Vertical Zooming. Pan allows separate Horizontal and Vertical Panning. Press ENTER to display the selected item. Press the ARROW buttons to adjust the selected item. These controls allow the user to setup custom or non-standard aspect ratios. Two sets of menus are available, one for HD inputs and another for SD inputs.

Note: Press ENTER to select the step size of the adjustment. Large (0.1), Medium (0.01) and Small (0.001) step sizes are indicated by the movement of the cursor on the value being adjusted. Press CONTRAST/JUMP to quickly jump between Separate H&V Zoom and Pan.

HD/SD Input Underscan
[No] Yes

The Input Underscan menu provides a convenient underscan mode, which is useful on CRT monitors that do not have underscan controls. This reduces the image by an additional 10 percent. Two sets of menus are available, one for HD inputs and another for SD inputs.

Output Configuration
Digital Output
SD Analog Output
SD Color
Analog NTSC Setup
Analog Setup Per Line
Test Pattern
Dual Rate
Oversample
HD Analog Output
HD Analog Sync Type

The Output Configuration menu includes additional settings as needed to configure the output. Once Output Configuration is reached within the Main Menu, press ENTER to access each Output Configuration submenu.

Digital Output
Follow Scaling
Always SD
Always HD
Reclocked Input

The Digital Output menu controls the operation of the SDI outputs. It can be set to follow scaling (default), always be SD, always be HD, or set to be reclocked copies of the input. This menu allows the SDI output format to be different from the analog output format.

If the digital output should match the analog output, select "Follow Scaling". However, if the digital output should always be SD or HD, regardless of the analog output, then select "Always SD" or "Always HD". This may be useful for driving a single-rate display, such as using an SD Digital monitor to view a dual-rate signal. If the 8024 is set to "Always SD," then if the input signal is SD, it will bypass scaling and go directly to the SDI outputs. However, if the input is HD, the signal will be downconverted to SD and sent to the SDI outputs.

This is done by setting the HD Input conversion to SD. Otherwise the HD downconversion does not take place and the "Always SD" outputs will be muted. Since the 8024 has only one scaler, the Digital Output "Always" functions are only available if the scaler is already converting the signal to the desired output or if the input matches the desired output.

Select "Reclocked Input" to route reclocked copies of the input (both video and audio, without scaling or delay) to the SDI outputs.

There are two additional reclocked copies always available, regardless of the above setting. Note: The Analog outputs always follow the scaler (SD or HD Input Conversion menu).

SD Analog Output
All Composite
Composite & Y/C
YPbPr BetaCam™ **
YPbPr MII™ **
YPbPr SMPTE **
GBR **

The SD Analog Output menu selects the format of the SD Analog output. Six types of SD analog outputs are available: All Composite, Composite and Y/C, YPbPr BetaCam™, YPbPr MII™, YPbPr SMPTE or GBR, all with embedded bi-level sync.

** The HD/SD analog encoder can support dual Composite and single Component/GBR operation but not dual Component/GBR. Thus, if both the HD/SD Analog and SD Analog Outputs are used simultaneously, only one output can be set to Component/GBR. If SD Analog Output is set to Component/GBR, then the HD Analog Output may not output Component/GBR until the SD Analog Output is reconfigured for Composite or Y/C.

If Dual Rate is set to HD & SD, the SD Analog output is shut down and both HD Component/GBR and SD Component/GBR are available on the HD/SD Analog output. This is possible because only one format, HD or SD, is available on the HD/SD Analog output at a time. The Dual Rate

mode of HD & SD is designed for dual-rate analog monitors that accept both HD and SD inputs on the same input connector.

SD Color
[Off] On

The SD Color menu enables the color for the SD Analog output.

Analog NTSC Setup
[Off] On

The Analog NTSC Setup menu enables the NTSC setup (pedestal) for the SD Analog output. This option turns on the setup for all lines. Turning off the setup for lines 10-25 may be performed below.

Analog Setup Per Line
Odd Field – Line 10 - 25
Even Field – Line 10 - 25

The Analog Setup Per Line menu enables the NTSC setup (pedestal) for the selected field and line on the SD Analog output. Press ENTER to access this submenu. Press UP or DOWN to select the desired field and line, then press RIGHT or LEFT to select Off or On. The main SD Analog NTSC Setup menu (above) must be set to On for this menu to take effect.

Test Pattern
[Off] On

The Test Pattern menu provides vertical lines for the HD Analog output and color bars for the SD Analog output.

Dual Rate
[HD Only] HD & SD

The Dual Rate menu selects which signals are available on the HD/SD Analog output.

Select "HD Only" to enable HD signals on the HD/SD Analog output. The HD/SD Analog output will be muted when converting to an SD signal. SD signals are now provided on the SD Analog output.

Select "HD & SD" to enable both HD and SD signals on the HD/SD Analog output. The SD Analog output will be muted.

The HD & SD mode allows a single connection to a multi-rate broadcast monitor, rather than two connections (HD & SD) that would force a user to select a different input as the standard changes between HD and SD.

Oversample
[16x SD] 2x HD

The Oversample menu selects the video quality of the SD and HD/SD Analog outputs. Oversampling increases video quality and can only be applied to either the SD or HD/SD Analog output, but not both simultaneously. Select 16x for SD (1x HD) or 2x for HD (4x SD). This allows the user to choose which analog output will have higher signal processing. This menu only applies if the Dual Rate mode is set to HD Only.

If the Dual Rate mode set to HD & SD, only the HD/SD Analog output is used and the highest sampling rate is automatically configured (16x for SD and 2x for HD).

HD Analog Output
[GBR] YPbPr

The HD Analog Output menu selects the format of the HD/SD Analog output. Select either GBR or YPbPr.

HD Analog Sync Type
H&V Video Bi-level Video Tri-level

The HD Analog Sync Type menu selects between H&V sync, Video Bi-level or Video Tri-level. If H&V external sync is selected, the embedded sync is removed for GBR signals and H&V are sent to the H&V connections on the HD/SD Analog output. If Bi-level or Tri-level sync is selected, the embedded sync is on all three output HD Analog channels (YPbPr or GBR).

Note: SD Analog signals always have normal bi-level sync.

Reticule Controls
Digital Reticules SD Analog Reticules HD Analog Reticules Center Cross (+) 4x3 Safe Area 4x3 Full Aperture 16x9 Safe Area Reticule Color Reticule Tracking

The Reticule Control menu controls the operation of the reticule overlays. Once Reticule Controls is reached within the Main Menu, press ENTER to access each Reticule Controls submenu.

Digital Reticules
[Off] On

SD Analog Reticules
[Off] On

HD Analog Reticules
[Off] On

The reticules are very flexible and can be enabled or disabled for any of the outputs: Digital (SDI), SD Analog and HD/SD Analog. Press LEFT or RIGHT to enable each output individually.

Reticule Settings
Off
On
User

Each of the four reticule types may be turned off, turned on (use default size and thickness), or user programmed with a custom size and thickness. Four sets of menus are available, one each of the different reticule types.

User Reticule Settings
Size
Thickness

The User Reticule Settings menu allows for customizing the reticules. Once User is reached within the Reticule Settings menu, press ENTER to access the User Reticule Settings submenu. Press LEFT or RIGHT to select between Size and Thickness. Then press ENTER to display the selected item. Press the ARROW buttons to adjust the selected item. These controls allow the user to setup custom reticules, such as for film aspect ratios or video aspect ratios specific to the project at hand. Four sets of menus are available, one each of the different reticule types.

Note: Press ENTER to select the step size of the adjustment. Large (0.1), Medium (0.01) and Small (0.001) step sizes are indicated by the movement of the cursor on the value being adjusted. Press CONTRAST/JUMP to quickly jump between Size and Thickness.

Reticule Color
Black
Blue
Red
Magenta
Green
Cyan
Yellow
White
Gray 1
Gray 2
Gray 3
User Settings

The Reticule Color menu allows for changing of the reticule color. Select between the default colors listed above, three levels of gray, or custom User Settings.

User Reticule Color
Y Gain
Saturation
Hue

The User Reticule Color menu provides custom control of the reticule color. Once User Settings is reached within the Reticule Color menu, press ENTER to access the user color submenu.

Press UP or DOWN to select between Y Gain, Saturation and Hue adjustments. Press LEFT or RIGHT to adjust the selected item.

Reticule Tracking
[Stay Put] Track

The Reticule Tracking menu controls the position of the reticules. The reticules can be locked to the display raster or configured to track the scaling video image. For example, if Track is selected, it would allow the user to zoom in on one size of the image and get a close view of the video with the reticule correctly positioned over the image. If Stay Put is selected, the reticules are locked to the display raster and are not effected by scaling the image.

Options
Video Y Gain
Video Saturation
Video Hue
Background Color
Encoder Over Sample
SD VBI
HD VBI
Motion Coprocessor
Dejitter Filter
HD-SD Color Matrix
Audio Delay Offset
Audio & Video Delay

The Options menu includes additional settings for video and audio control. Once Options is reached within the Main Menu, press ENTER to access each Options submenu.

Video Y Gain
100 IRE

This menu provides Video Proc control of Y Gain to the signal. This is similar to adjusting the contrast of the image. A value of 100 IRE provides no gain or attenuation to the signal.

Video Saturation
100 IRE

This menu provides Video Proc control of Saturation to the signal. This is similar to adjusting the color of the image. A value of 100 IRE provides no gain or attenuation to the signal. A value of 0 provides a black & white image.

Video Hue
0.00°

This menu provides Video Proc control of Hue to the signal. This is similar to adjusting the tint of the image. A value of 0.00° provides no alteration of hue to the signal. Adjust the Hue as desired to compensate for signals with incorrect colors.

Background Color
Black
Blue
Red
Magenta
Green
Cyan
Yellow
White
Gray 1
Gray 2
Gray 3
User Settings

The Background Color menu allows for changing of the background color. The background is the part of the video surrounding the image, such as the bars above and below the image in Letterbox mode, or surrounding the image if it has been zoomed out so the image does not fill the entire screen. Select between the default colors listed above, three levels of gray, or custom User Settings.

User Background Color
Y Gain
Saturation
Hue

The User Background Color menu provides custom control of the background color. Once User Settings is reached within the Background Color menu, press ENTER to access the user color submenu. Press UP or DOWN to select between Y Gain, Saturation and Hue adjustments. Press LEFT or RIGHT to adjust the selected item.

Encoder Oversample
Off [On]

The Encoder Oversample menu selects if the Encoder will over sampled or not.

HD/SD VBI
Off [On]

The VBI menu selects if VBI will be enabled or not. Two sets of menus are available, one for HD inputs and another for SD inputs.

Motion Coprocessor
Off [On]

The Motion Coprocessor menu selects if advanced deinterlacing with motion adaption is active. Turning this function off disables advanced deinterlacing which may produce undesirable video artifacts.

Auto Motion Detect
Off [On]

The Auto Motion Detect menu selects if the adaptive motion detection algorithm is enabled or not. Turning this function off reduces the quality of the advanced deinterlacing which may produce undesirable video artifacts.

Dejitter Filter
Off [On]

The Dejitter Filter menu enables the internal dejitter filter, providing a more stable signal by reducing clock jitter.

Auto Color Matrix
Off [On]

The Auto Color Matrix menu enables the automatic color space conversion matrix. Select On to automatically apply the appropriate color space conversion to the signal as required for SD-to-HD or HD-to-SD conversions. SD-to-SD and HD-to-HD conversions will automatically not have the color space conversion applied. Select off to not apply any color space conversion to the signal, regardless of the video conversion in use.

Audio Delay Offset
-100 to 1000 milliseconds

The Audio Delay Offset menu provides a means to delay or advance the audio being processed by the 8024. This may be useful to correct for mismatched audio and video timing that enters the unit. Select an audio delay between -100 and +1000 milliseconds. A setting of 0 will delay the audio to match the video delay as listed under Audio & Video Delay. A positive setting will delay the audio after the video. A negative setting will advance the audio before the video. Audio delay is only provided for the SDI input to image processed SDI outputs. It is not available if "Digital Output" is set to "Reclocked Input." The minimum Total Audio Delay (see below) available is 33ms. Audio Delay Offsets resulting in Total Audio Delay of less than 33ms will have no effect.

Audio & Video Delay
Audio Delay = 50ms
Video Delay = 50ms

The Audio Delay indicates the total amount of audio processing delay provided by the 8024. The Audio Delay is adjusted using the Audio Delay Offset (see above).

The Video Delay indicates the total amount of video processing delay provided by the 8024. The Video Delay is not adjustable. The amount video delay depends on the input and output formats.

Video Delay + Audio Offset = Audio Delay.

Utilities
Power & Temperature
Remote Control
Unit Address
Clear All Presets
Factory Defaults
Versions
Self Tests
LCD Menu Timeout

The Utilities menu provides additional settings for operation of the 8024, not related to controlling video or audio. Once Utilities is reached within the Main Menu, press ENTER to access each Utilities submenu.

Power & Temperature
Main Power Supply
Aux Power Supply
Front Panel Temperature
Front Panel Maximum
Scaler Temperature
Scaler Maximum
Main Power Alarm
Aux Power Alarm
Temperature Alarm

The Power & Temperature menu provides status on the operation of the 8024 and control of certain alarm conditions. Once Power & Temperature is reached within the Utilities Menu, press ENTER to access the Power & Temperature submenu.

Main Power Supply displays the voltage of the power provided at the Main power connector.
 Aux Power Supply displays the voltage of the power provided at the Aux power connector.

Front Panel Temperature displays the temperature of the front panel. Press RIGHT to cycle between °C or °F. Front Panel Maximum displays the maximum temperature reached since this value was last reset. Press RIGHT to reset this value. Scaler Temperature displays the temperature of the scaler. Press RIGHT to cycle between °C or °F. Scaler Maximum displays the maximum temperature reached since this value was last reset. Press RIGHT to reset this value.

Alarms may be enabled to alert the user when certain conditions exist. If the Main or Aux input power is too low or too high for proper operation, the 8024 can display a message to the user that further investigation is necessary. If the temperature rises to a dangerous level, the 8024 can indicate this too.

The power alarms are useful for a unit with redundant power supplies. If either power supply fails, a message can alert the user about the failed supply. The user then has the opportunity to correct the problem while the unit is still being powered by the working power supply. The Main Power and Temperature alarms are enabled by default. The Aux Power alarm must be enabled manually. If only Main Power is used and Aux Power is not provided, the Aux Power Alarm should remain disabled to prevent unwanted power messages. Turn on the desired alarm to activate the messages. All settings are retained if the unit is turned off or loses power.

Remote Control
Off <input checked="" type="checkbox"/> Active <input type="checkbox"/> Passive

The Remote Control menu controls the communication between the Front Panel, Scaler and PC. Select Off to disable all communication. The Front Panel will still function and save any changed settings, but it will not control the Scaler or receive commands from a PC. Select Active (default) for normal operation. The Front panel will control the scaler as normal. It will also receive commands from a PC, interpret them and change the settings within the Front Panel and Scaler. Select Passive to allow the Front Panel to pass commands from the PC directly to the scaler. The Front Panel will still function and save any changed settings, but only the PC will control the scaler.

The 8024 will always return to the Active setting when powered up or a Factory Default is performed. This setting is not stored in memory.

Unit Address
0 – 255

The Unit Address is used when multiple units are being controlled from a PC. Set each unit to a different address (default = 1), then select which address to control from within the PC program.

Clear All Presets
<input type="checkbox"/> No <input checked="" type="checkbox"/> Yes

The Clear All Presets menu allows clearing of all presets within the 8024 and return them to their default condition. Select Yes, then press ENTER to select this item. "Are You Sure?" will appear on the LCD screen. Select Yes again, then press ENTER to confirm operation of this command. Select No or press EXIT to abort this command. Once activated, all presets will be cleared and the clearing progress will be displayed on the LCD.

Note: Clearing Presets will also reset the current operation of the unit. See Preset Menu for detailed operation of the Presets.

Factory Defaults
<input type="checkbox"/> No <input checked="" type="checkbox"/> Yes

The Factory Defaults menu allows clearing of all settings (except Presets) within the 8024 and return them to their default condition. Select Yes, then press ENTER to select this item. "Are You Sure?" will appear on the LCD screen. Select Yes again, then press ENTER to confirm operation of this command. Select No or press EXIT to abort this command. Once activated, all settings (except Presets) will be cleared and the current operation of the unit will return to its default state.

Versions
Scaler PIC
Scaler FPGA
Scaler EPLD
Scaler Bootloader
Scaler Filter
Scaler Unit Type
Front Panel PIC
Front Panel Bootloader

The Versions menu displays the version of each code currently programmed in the unit. Once Versions is reached within the Utilities Menu, press ENTER to access the Versions submenu.

Self Tests
All Tests
Power Test
Temperature Test
EEPROM Test
LCD Test
Button Test
LED Test
RS-232 Test

The Self Test menu provides a means for testing the front panel hardware. It does not test the operation of the video scaler or the functionality of any code. Once Self Tests is reached within the Utilities Menu, press ENTER to access the Self Tests submenu. Select which test to run using the LEFT and RIGHT arrows. All remaining tests after testing has begun will be performed. Press ENTER to continue to the next test or EXIT to abort testing. Follow the instructions on the LCD. The operator must manually verify each test.

LCD Menu Timeout
Off, 3-250 Seconds

The LCD Menu Timeout selects how long the LCD Menu will remain at its current menu, without any buttons being pushed, before automatically returning to the Main Screen. Select between 3 and 250 Seconds. Select Off to prevent the LCD menu from returning to the Main Screen. This requires the user to manually exit out of any menu to reach the Main Screen.

Note: Only the Input format, Output format, if input signal is detected and alarm conditions are shown on the Main Screen.

Remote Control

The 8024 includes remote control capability using a PC running Microsoft Windows™. The optional remote control kit requires an RS-232 standard serial cable (straight-thru, not a null-modem cable) and remote control software. All video controls that are available through the front panel, including Presets, are also available using the PC program. Additional information may be found in the Remote Control program Help menu.

GPIO

The 8024 includes general purpose inputs and outputs. These include 6 local inputs, 4 isolated inputs and 2 local outputs. All 10 inputs recall Presets 1 – 10. This allows recalling a previously-saved Preset to control the unit without having to use the front panel or remote control. The local inputs and outputs use a common ground system within the 8024. These are designed to be used near the 8024 where isolation to the unit is not necessary. The isolated inputs are optically isolated from the 8024. They have an isolated ground system designed for use where long cable runs, such as between two buildings, would include a difference of potential between the two grounds. The isolated inputs require supplying an isolated +5VDC power source to the isolated switches. An option to configure the isolated inputs using local power and local ground is available. This removes the isolation feature of these inputs, but allows all 10 inputs to be used locally. Switches, LEDs and other hardware are to be supplied locally. See the wiring drawing below for information on how to connect the GPIO switches and LEDs.

GPIO Connections

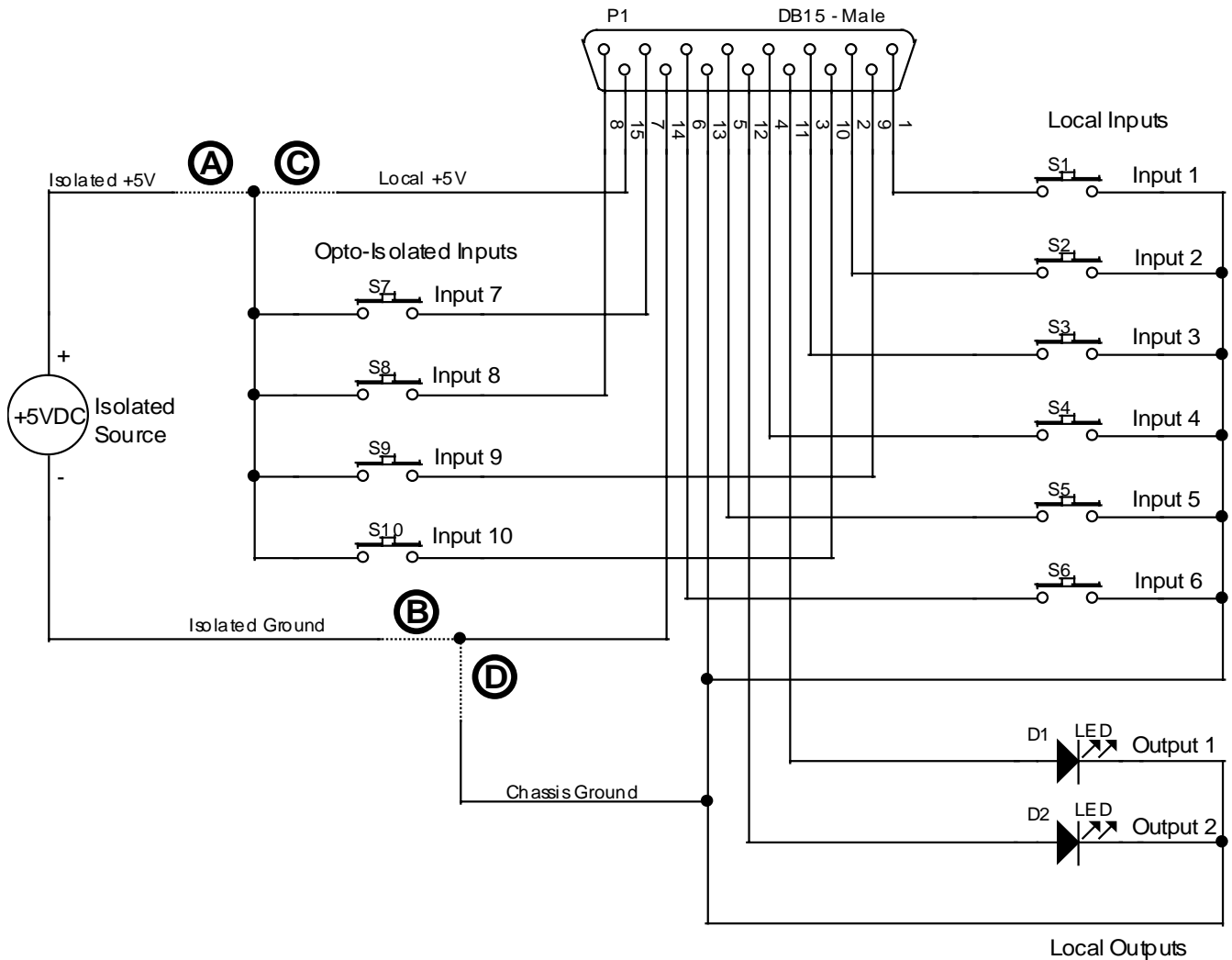

Inputs 1 - 6 are Dry Contacts: Connect to Chassis Ground (pin 13).
 Inputs 7 - 10 are Opto-Isolated: Supply Isolated +5V to switches. (Connection A)
 Also connect Isolated Ground to pin 14. (Connection B)
 Do not make connections C or D.
 Outputs 1 - 2: Internal resistors are included for standard LEDs. Lo = Off, Hi = On.

Note:

Optionally may use Local +5V to drive Inputs 7-10:
 Omit Isolated Source and connect Local +5V (pin 15) to switches. (Connection C)
 Also connect Chassis Ground (pin 13) to pin 14. (Connection D)
 Do not make connections A or B.
 Opto-isolation is not provided in this configuration.

Delay Characteristics

The processing delay varies with the type of conversion being performed. The charts below list the electrical length or processing time for the HD/SD-SDI and Analog HD/SD outputs. The first chart is for 1080 outputs, the second for 720 outputs and the third for XGA and SD outputs. Select the input rate on the left and the output rate and type on the top. The intersecting box contains the conversion time information. Values listed do not include advanced deinterlacing provided by the Motion Coprocessor.

f = field; F = Frame; Delay rates (in f or F) are shown with respect to the input signal.

From → To	HD 1080 (SDI or Analog Output)		HD 1080 (SDI or Analog Output)	
1080 sF 23.98	i 29.97	1/13.32-1/11.99 sec – 3.6-4f	sF/p 23.98	1/11.99 sec – 4f
1080 p 23.98	i 29.97	1/13.32-1/11.99 sec – 1.8-2F	p/sF 23.98	1/11.99 sec – 2F
1080 sF 24	i 30	3/40-1/12 sec – 3.6-4f	p 24	1/12 sec – 4f
1080 p 24	i 30	3/40-1/12 sec – 1.8-2F	sF 24	1/12 sec – 2F
1080 i 25	i 25	1/25 sec – 2f	p 25	1/12.5 sec – 2f
1080 p 25	i 25	1/12.5 sec – 2F	p 25	1/12.5 sec – 2F
1080 i 29.97	i 29.97	1/30 sec – 2f	p 29.97	1/14.98 sec – 2f
1080 p 29.97	i 29.97	1/15 sec – 2F	p 29.97	1/14.98 sec – 2F)
1080 i 30	i 30	1/30 sec – 2f	p 30	1/15 sec – 4f
1080 p 30	i 30	1/15 sec – 2F	p 30	1/15 sec – 2F
720 p 25	i 25	1/12.5 sec – 2F	p 25	1/12.5 sec – 2F
720 p 29.97	i 29.97	1/14.98 sec – 2F	p 29.97	1/14.98 sec – 2F
720 p 30	i 30	1/15 sec – 2F	p 30	1/15 sec – 2F
720 p 50	i 25	1/25 sec – 2F	p 50	1/50 sec – 1F
720 p 59.94	i 29.97	1/29.97 – 2F	p 29.97	1/14.98 – 4F
720 p 60	i 30	1/30 sec – 2F	p 30	1/15 – 4F
486 i 29.97	i 29.97	1/29.97 – 2f	p 29.97	1/14.98 – 4f
575 i 25	i 25	1/25 – 2f	p 25	1/25 – 4f

f = field; F = Frame; Delay rates (in f or F) are shown with respect to the input signal.

From → To	HD 720 (SDI or Analog Output)		HD 720 (SDI or Analog Output)	
1080 sF 23.98	----		p 59.94	1/13.32-1/11.99 sec – 3.6-4f
1080 p 23.98	----		p 59.94	1/13.32-1/11.99 sec – 1.8-2F
1080 sF 24	----		p 60	3/40-1/12 sec – 3.6-4f
1080 p 24	----		p 60	3/40-1/12 sec – 1.8-2F
1080 i 25	p 25	1/25 sec – 4f	p 50	1/25 sec – 2f
1080 p 25	p 25	1/12.5 sec – 2F	p 50	1/12.5 sec – 2F
1080 i 29.97	p 29.97	1/29.97 sec – 4f	p 59.94	1/29.97 sec – 2f
1080 p 29.97	p 29.97	1/14.98 sec – 2F	p 59.94	1/14.98 sec – 2F
1080 i 30	p 30	1/15 sec – 4f	p 60	1/15 sec – 4f
1080 p 30	p 30	1/15 sec – 2F	p 60	1/15 sec – 2F
720 p 25	p 25	1/12.5 sec – 2F	p 50	1/12.5 sec – 2F
720 p 29.97	p 29.97	1/14.98 sec – 2F	p 59.94	1/14.98 sec – 2F
720 p 30	p 30	1/15 sec – 2F	p 60	1/15 sec – 2F
720 p 50	p 25	1/12.5 sec – 4F	p 50	1/50 sec – 2F
720 p 59.94	p 29.97	1/14.98 sec – 4F	p 59.94	1/29.97 sec – 2F
720 p 60	p 30	1/15 sec – 4F	p 60	1/30 sec – 2F
486 i 29.97	p 29.97	1/14.98 sec – 4f	p 59.94	1/29.97 sec – 2f
575 i 25	p 25	1/12.5 sec – 4f	p50	1/25 sec – 2f

Delay Characteristics (continued)

f = field; F = Frame; Delay rates (in f or F) are shown with respect to the input signal.

From → To	XGA 1024x768 (Analog output)	SD-SDI or SD-Analog Output 486 = NTSC & 575 = PAL
1080 sF 23.98	p 59.94 1/13.32-1/11.99 sec – 3.6-4f	486 i 29.97 1/13.32-1/11.99 sec – 3.6-4f
1080 p 23.98	p 59.94 1/13.32-1/11.99 sec – 1.8-2F	486 i 29.97 1/13.32-1/11.99 sec – 1.8-2F
1080 sF 24	p 60 3/40-1/12 sec – 3.6-4f	----
1080 p 24	p 60 3/40-1/12 sec – 1.8-2F	----
1080 i 25	p 50 1/25 sec – 2f	575 i 25 1/25 sec – 2f
1080 p 25	p 50 1/12.5 sec – 2F	575 i 25 1/12.5 sec – 2F
1080 i 29.97	p 59.94 1/29.97 sec – 2f	486 i 29.97 1/29.97 sec – 2f
1080 p 29.97	p 59.94 1/14.98 sec – 2F	486 i 29.97 1/14.98 sec – 2F
1080 i 30	p 60 1/15 sec – 4f	----
1080 p 30	p 60 1/15 sec – 2F	----
720 p 25	p 50 1/12.5 sec – 2F	575 i 25 1/12.5 sec – 2F
720 p 29.97	p 59.94 1/14.98 sec – 2F	486 i 29.97 1/14.98 sec – 2F
720 p 30	p 60 1/15 sec – 2F	----
720 p 50	p 50 1/50 sec – 2F	575 i 25 1/25 sec – 2F
720 p 59.94	p 59.94 1/29.97 sec – 2F	486 i 29.97 1/29.97 sec – 2F
720 p 60	p 60 1/30 sec – 2F	----
486 i 29.97	p 59.94 1/29.97 sec – 2f	486 i 29.97 1/29.97 sec – 2f
575 i 25	p50 1/25 sec – 2f	575 i 25 1/25 sec – 2f

Specifications

DIGITAL INPUTS

Input – Dual-Rate SMPTE-292 HDSI (10-bit) and SMPTE259M-C (10-bit)
◆ HD: 720 i25/29.97/30/59.94/60 and p/23.98/24: embedded in p59.94/60
◆ HD: 1080 i23.98.59.94/60/50 - p25/29.97/30 - p/sF 23.98/24
◆ SD: 486 i29.97 NTSC - 575 i25 PAL

Input Equalization: 330ft (100 Meters) Belden 1505A
Return Loss: > 15 dB

DIGITAL OUTPUTS

Active Loop Two HD or SD SDI reclocked copies of input (Dual-Rate)
Processed Dual SMPTE-292 HDSI (10-bit) and SMPTE259M-C (10-bit)
◆ HD: 720 i25/29.97/30/59.94/60 and 24: embedded in 60p
◆ HD: 1080 i23.98.59.94/60/50
◆ HD: 1080 p25/29.97/30 23.98/24p/sF
◆ HD: 488 i30 NTSC
◆ HD: 576 i25 PAL

Return Loss: > 15 dB
Connectors: Four BNCs

IMAGE PROCESSING

Scaling: 24-tap poly-phase with 10-bit processing
Resizing: Full zoom and pan functions (2-axis DVE)
Presets for Letterbox, Pillar Box and Center Cut
Film Modes: 3:2 pull down, interlaced to progressive and progressive to interlaced

ANALOG OUTPUTS

Output Signal: HD, SD and XGA Analog
HD – YPbPr or GBR
SD – Composite, Y/C, Component (BetaCam™, MII™, SMPTE) or GBR
XGA – 1024x768 at various frame rates

Frequency Response: HD/XGA: Y/GBR: 0-28 MHz +/- 0.25 dB
Pb/Pr: 0-13 MHz +/- 0.25 dB
SD: 0-5.2 MHz +/- 0.25 dB

Encoding Path: 12-bit encoding and DAC – 10-bit input
Return Loss: >36dB
Connectors: HD Analog: HD15 Dsub (may use BNC breakout cable)
SD Analog: HD15 Dsub (may use BNC breakout cable)
Sync: HD Analog: H&V, Bi-level or Tri-level sync on video
SD Analog: Bi-level sync on video

RETICULES

Types: Center Cross, 4x3 Safe Area, 4x3 Full Aperture and 16X9 Safe Area
- each type can be individually enabled and user size adjusted
Reticule Color: Black, White or User defined
Reticule Outputs: Individually enabled for each output (Digital, HD Analog, SD Analog)

ENVIROMENT

Operating Range: 40-100 °F (4.4-37.8 °C) (non-condensing)
Input Power: + 7 to 18 VDC @ 15 watts
Options: Redundant power supply
PC Remote Control
1U Rack Mount Kit
Size LxWxH: 13.9 x 8.7 x 1.7" (353 x 221 x 43 mm)

This product is not authorized for use in life support systems. Product liability is limited only to replacement of this unit. Cobalt Digital Inc. does not assume any liability for loss of use due to failure of this component.

Specifications subject to change without notice.

Cobalt Digital Inc.
www.cobaltdigital.com

2406 E. University Avenue, Urbana, IL 61802
Rev. 0.5 TJH

Office: 217-344-1243 Fax: 217-344-1245
Copyright 2005 Cobalt Digital Inc.