

# 9003

## Dual HD/SD SDI Reclocking Distribution Amplifier

# Owner's Manual



9003-OM  
Version: 1.0



---

## 9003 • Dual HD/SD Reclocking Distribution Amplifier Owner's Manual

- Cobalt Part Number: **9003-OM**
- Document Version: **1.0**
- Printed in the United States.
- Last Author: KGM
- Printing Date: 12/11/07 3:34 PM

The information contained in this Owner's Manual is subject to change without notice or obligation.

---

### Copyright

© 2007 Cobalt Digital Inc. All rights reserved.

Contents of this publication may not be reproduced in any form without the written permission of Cobalt Digital Inc. Reproduction or reverse engineering of copyrighted software is prohibited.



---

### Notice

The material in this manual is furnished for informational use only. It is subject to change without notice and should not be construed as a commitment by Cobalt Digital Inc. Cobalt Digital Inc assumes no responsibility or liability for errors or inaccuracies that may appear in this manual.

---

### Trademarks

-  is a registered trademark of Ross Video Limited.
-  is a registered trademark of Cobalt Digital Inc.
- All other product names and any registered and unregistered trademarks mentioned in this manual are used for identification purposes only and remain the exclusive property of their respective owners.

---

## Important Regulatory and Safety Notices

Before using this product and any associated equipment, refer to the “Important Safety Instructions” listed below so as to avoid personnel injury and to prevent product damage.

Products may require specific equipment, and /or installation procedures be carried out to satisfy certain regulatory compliance requirements. Notices have been included in this publication to call attention to these specific requirements.

### Symbol Meanings



This symbol on the equipment refers you to important operating and maintenance (servicing) instructions within the Product Manual Documentation. Failure to heed this information may present a major risk of damage or injury to persons or equipment.



**Warning**

The symbol with the word “**Warning**” within the equipment manual indicates a potentially hazardous situation, which if not avoided, could result in death or serious injury.



**Caution**

The symbol with the word “**Caution**” within the equipment manual indicates a potentially hazardous situation, which if not avoided, may result in minor or moderate injury. It may also be used to alert against unsafe practices.



**Notice**

The symbol with the word “**Notice**” within the equipment manual indicates a situation, which if not avoided, may result in major or minor equipment damage or a situation which could place the equipment in a non-compliant operating state.



**ESD  
Susceptibility**

This symbol is used to alert the user that an electrical or electronic device or assembly is susceptible to damage from an ESD event.

### Important Safety Instructions



**Caution**

This product is intended to be a component product of the openGear™ frame. Refer to the openGear™ frame Owner’s Manual for important safety instructions regarding the proper installation and safe operation of the frame as well as it’s component products.



**Warning**

Certain parts of this equipment namely the power supply area still present a safety hazard, with the power switch in the OFF position. To avoid electrical shock, disconnect all A/C power cords from the chassis' rear appliance connectors before servicing this area.



**Warning**

Service barriers within this product are intended to protect the operator and service personnel from hazardous voltages. For continued safety, replace all barriers after any servicing.

This product contains safety critical parts, which if incorrectly replaced may present a risk of fire or electrical shock. Components contained within the product’s power supplies and power supply area, are not intended to be customer serviced and should be returned to the factory for repair.

To reduce the risk of fire, replacement fuses must be the same type and rating.

Only use attachments/accessories specified by the manufacturer.

## Environmental Information

**The equipment that you purchased required the extraction and use of natural resources for its production. It may contain hazardous substances that could impact health and the environment.**

To avoid the potential release of those substances into the environment and to diminish the need for the extraction of natural resources, Cobalt Digital encourages you to use the appropriate take-back systems. These systems will reuse or recycle most of the materials from your end-of-life equipment in an environmentally friendly and health conscious manner.

The crossed-out wheeled bin symbol invites you to use these systems.

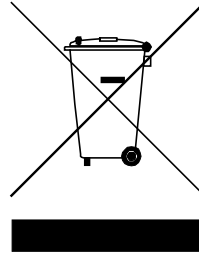

If you need more information on the collection, reuse, and recycling systems, please contact your local or regional waste administration.

You can also contact Cobalt Digital for more information on the environmental performances of our products.

# openGear Contents

<b>Introduction</b>	<b>6</b>
In This Chapter.....	6
A Word of Thanks.....	6
Overview.....	6
Functional Block Diagram.....	7
Supported Serial Rates.....	8
Documentation Terms.....	8
<b>Installation and Setup</b>	<b>9</b>
In This Chapter.....	9
Static Discharge.....	9
Unpacking.....	9
Rear Module Installation (Optional).....	10
Board Installation.....	11
Cable Connections.....	11
Card Control and Status.....	12
Card Status.....	12
Switches.....	12
<b>Remote Control</b>	<b>13</b>
In This Chapter.....	13
DashBoard Control System Software.....	13
<b>Service Information</b>	<b>15</b>
In This Chapter.....	15
Troubleshooting Checklist.....	15
Warranty and Repair Policy.....	16
<b>Ordering Information</b>	<b>17</b>
9003 and Related Products.....	17
<b>Contact Us</b>	<b>18</b>
Contact Cobalt Digital Inc.....	18
Visit us at the Cobalt Digital Inc. website.....	18

# Introduction

---

## In This Chapter

This chapter includes the following sections:

- A Word of Thanks
- Overview
- Functional Block Diagram
- Supported Audio and Video Formats
- Documentation Terms

---

## A Word of Thanks

Congratulations on choosing the openGear™ 9003 Dual HD/SD Reclocking Distribution Amplifier. The 9003 is part of a full line of modular conversion gear for broadcast TV environments. The Cobalt Digital openGear™ line includes video decoders and encoders, audio embedders and de-embeders, distribution amplifiers, format converters, and much more. Cobalt openGear™ modular conversion gear will meet your signal conversion and distribution needs now and well into the future.

Should you have questions pertaining to the installation or operation of your 9003, please contact us at the numbers listed on the back cover of this manual. We are happy to help with any questions regarding this or any other openGear™ card.

---

## Overview

The 9003 is a high quality two channel, Dual HD/SD Reclocking Distribution Amplifier. It is capable of equalizing and reclocking two channels in HD or SD.

The card has two HD/SD-SDI inputs, labeled “SDI Input 1” and “SDI Input 2”. The card has two sets of four SDI outputs labeled “SDI output A” and “SDI output B”. The outputs of the four BNCs in each set always emit the same data.

There are four routing modes available on the card.

- 1) Input 1 → Output A, Input 2 → Output B
- 2) Input 1 → Output A, Input 1 → Output B
- 3) Input 2 → Output A, Input 2 → Output B

- 4) Failover mode: Input 1 → Output A&B, until Input 1 loses lock, then Input 2 → Outputs A&B if input 1 is restored the card uses it again.

The 9003 can equalize and reclock incoming SDI signal using up to 300m of cable at 270 Mbps and up to 120m of cable at 1.485 Gbps.

---

## Functional Block Diagram

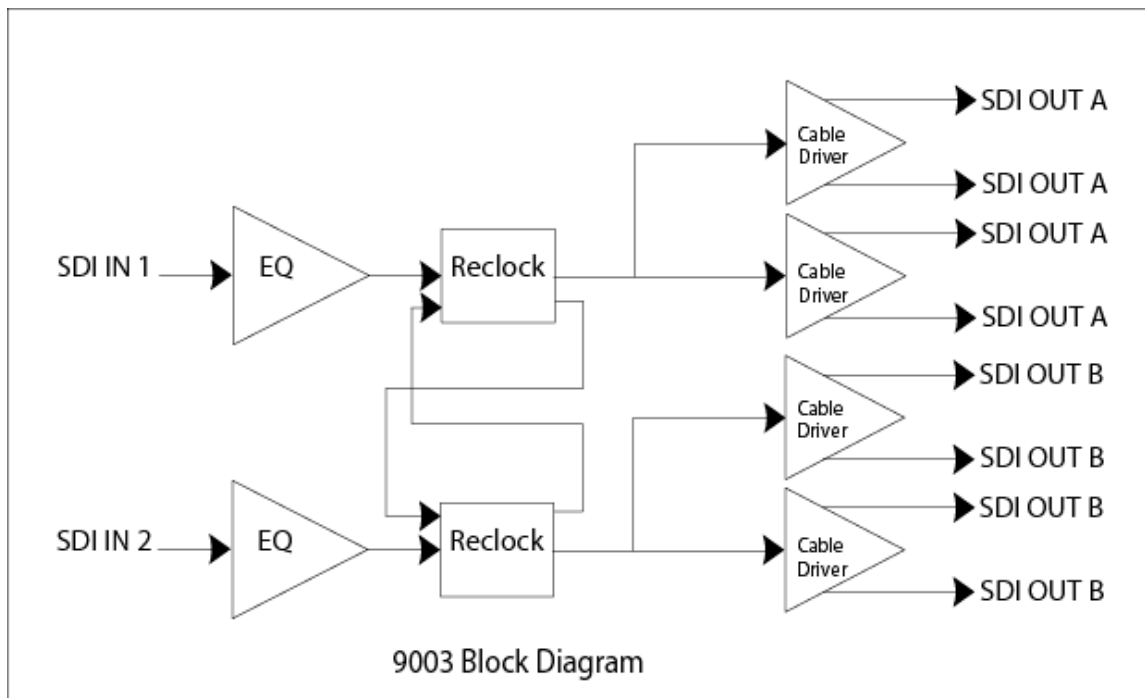

---

## Supported Serial Rates

The 9003 will reclock 270 Mbps, 1.485 Gbps, and 1.4835 Gbps signals. Signals of other rates will be equalized and distributed to the outputs, and the reclocker will be bypassed.

---

## Documentation Terms

The following terms are used throughout this guide:

- “**Frame**” refers to the **8310** frame that houses the **9003** card.
- “**Operator**” and “**User**” both refer to the person who uses the **9003**.
- “**Board**” and “**Card**” all refer to the **9003** card itself, including all components and switches.
- “**System**” and “**Video system**” refers to the mix of interconnected production and terminal equipment in which the **9003** operates.

# Installation and Setup

---

## In This Chapter

This chapter includes the following sections:

- Static Discharge
- Unpacking
- Rear Module Installation (Optional)
- Board Installation
- BNC Connections
- Menu Structure
- Factory Defaults

---

## Static Discharge

Whenever handling the card and other related equipment, please observe all static discharge precautions as described in the following note:



**ESD  
Susceptibility**

Static discharge can cause serious damage to sensitive semiconductor devices. Avoid handling circuit boards in high static environments such as carpeted areas, and when wearing synthetic fiber clothing. Always exercise proper grounding precautions when working on circuit boards and related equipment.

---

## Unpacking

Unpack each card you received from the shipping container, and check the contents against the packing list to ensure that all items are included. If any items are missing or damaged, contact your sales representative or Cobalt Digital directly.

---

## Rear Module Installation (Optional)

If you are installing the card in a 8310-C-BNC or 8310-BNC frame (one with a 100 BNC rear module installed across the entire back plane), skip this section.

If you are installing the card into a slot with no rear module, you should have ordered and received a RM-9003-A Rear Module with your card. You will need to install it in your 8310 frame before you can connect cables.

Use the following steps to install the RM-9003-A in an 8310 openGear™ frame:

1. Refer to the openGear™ 8310 frame Owner's Manual, to ensure that the frame is properly installed according to instructions.
2. On the rear of the 8310, locate the card frame slot.
3. As shown in Figure 2, seat the bottom of the RM-9003-A in the seating slot at the base of the frame's back plane.

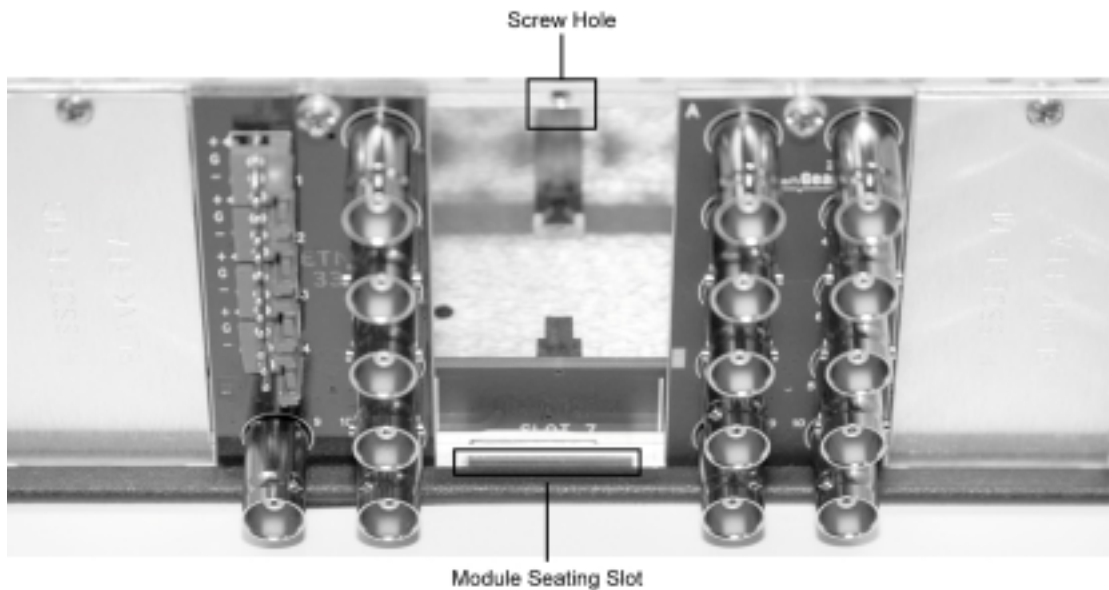

Figure 2. Rear Module Installation

4. Align the top hole of the RM-9003-A with the screw hole on the top edge of the 8310 back plane.
5. Using a Phillips driver and the supplied screw, fasten the RM-9003-A panel to the 8310 back plane. Do not over tighten.

This completes the procedure for installing the RM-9003-A in an 8310 openGear™ frame.

---

## Board Installation

Use the following steps to install the card in the openGear™ 8310 frame:

1. Refer to the Owner's Manual of the openGear™ 8310 frame to ensure that the frame is properly installed according to instructions.



**Warning**

Heat and power distribution requirements within a frame may dictate specific slot placement of cards. Cards with many heat-producing components should be arranged to avoid areas of excess heat build-up, particularly in frames using convection cooling.

2. After selecting the desired frame installation slot, hold the card by the edges and carefully align the card edges with the slots in the frame. Then, fully insert the card into the frame until the rear connection plugs are properly seated on the midplane and rear modules.

This completes the procedure for installing the card in the openGear™ 8310 frame.

---

## Cable Connections

This section provides instructions for connecting cables to the installed BNC rear modules on the 8310 series frame backplane. Connect the input and output cables according to the following diagram. The input is internally terminated with 75 Ohms. It is not necessary to terminate unused outputs.

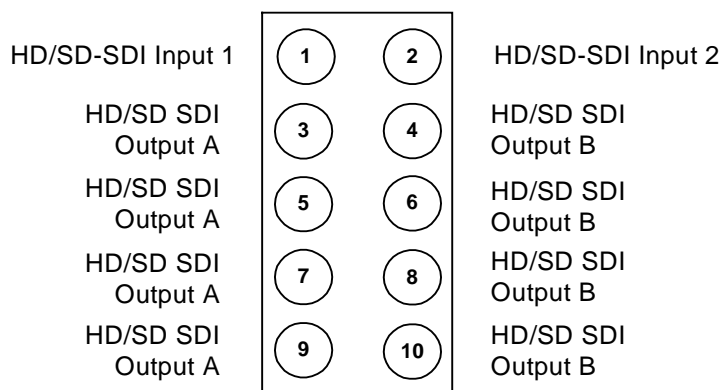

Figure 3. BNC Designations for the Card Rear Module RM-9003-A or 8310-RM-100

---

# Card Control and Status

## Card Status

The card has an LED that indicates whether Dashboard remote control is enabled, or if the switch bank controls the card. See description of switch 1 below.

The first bank of four LED's indicates the routing mode. There will be one LED illuminated for output A and one illuminated for output B, indicating from which input each output is being routed.

The card also indicates the status of each of the outputs signal with the two banks of four LEDs labeled with the different supported formats (1080, 720, 625, 525). When the card has locked to a particular output format, that LED will be illuminated. When the card has not locked to a particular video format, the card will search all possible formats, and the lights will cycle rapidly.

## Switches

There is a bank of eight switches (S1) on the front edge that controls the card.

Segment	Function
<b>1</b>	<b>Up – Remote control Enabled*</b> <b>Down – Remote Control Disabled</b>
<b>2 3</b>	<b>Selects Routing</b>
ON ON	In 1 → Out A, In 2 → Out B
ON OFF	In 1 → Out A, In 1 → Out B
OFF ON	In 2 → Out A, In 2 → Out B
OFF OFF	Failover (Selects In 1 when present, otherwise In 2)
<b>4 5</b>	<b>Selects Rate for Out A</b>
ON ON	Automatic rate determination
ON OFF	Reserved
OFF ON	1.4835/1.485 Gbps
OFF OFF	270 Mbps
<b>6 7</b>	<b>Selects Rate for Out B</b>
ON ON	Automatic rate determination
ON OFF	Reserved
OFF ON	1.4835/1.485 Gbps
OFF OFF	270 Mbps
<b>8</b>	<b>Switch 8 is reserved</b>

\* Switch 1 controls the behavior of the rest of the switches. With switch 1 set in the up position, Dashboard remote control software can change the settings of the card. Consequently the rest of the onboard switches will have no effect. With switch 1 set in the down position, Dashboard remote control software is prevented from making changes to the card settings. Consequently the onboard switches 2-8 control the settings.

The factory default settings are as follows

- 1) Remote Control is enabled.
- 2) Routing is In 1 ->Out A, In 2 ->Out B.
- 3) Rates A and B are set to Auto.

# Remote Control

---

## In This Chapter

This section provides a detailed explanation on using remote control functions with your card.

---

## DashBoard Control System Software

The DashBoard Control System enables you to monitor and control openGear™ frames and controller cards from a computer. The DashBoard software and manual can be downloaded from the Cobalt Digital Inc. website.

### *Using the Menus*

You must first install the DashBoard Control System software on your computer. Refer to the *DashBoard User Manual* for software installation procedures and for using the DashBoard interface.

## The Menu System

The following table and sections describe the menus, items, and parameters available from the DashBoard Control System software for the card.

Table 3. DashBoard Menus

Menu	Item	Parameters	Description
<b>Card Info (Read-only)</b>	Product	CDI-9003	
	Manufacturer	Cobalt Digital Inc.	
	Serial Number	#####	Displays the Silicon Serial Number of the card.
	Temperature		Temperature of on card sensor
	Input Current		Current consumed from +12V rail
	Input Voltage		Measured voltage of +12V rail

<b>Control</b>	Remote Control	Enabled/Disabled	This shows whether the remote is enabled (S1-1 on the board is up)
	Routing	In 1→Out A, In 2→Out B In 1→ Out A & B In 2 → Out A & B Fail-Safe	Routes outputs A & B from either their respective inputs, or both from one of the two inputs.
	Rate A	Automatic 2.967/2970 Gbps 1.4835/1.485Gbps 270 Mbps	This forces the reclocker to only run at the specified rate. “Automatic” means the reclocker will detect the input rate and relock it.
	Lock Status A		Describes the current input rate
	Rate B	Automatic 2.967/2970 Gbps 1.4835/1.485Gbps 270 Mbps	This forces the reclocker to only run at the specified rate. “Automatic” means the reclocker will detect the input rate and relock it.
	Lock Status B		Describes the current input rate

# Service Information

---

## In This Chapter

This chapter includes the following sections:

- Troubleshooting Checklist
- Warranty and Repair Policy

---

## Troubleshooting Checklist

Routine maintenance to this openGear™ product is not required. In the event of problems with your card, the following basic troubleshooting checklist may help identify the source of the problem. If the module still does not appear to be working properly after checking all possible causes, please contact your openGear™ products distributor, or the Technical Support department at the numbers listed under the “Contact Us” section at the end of this manual.

1. **Visual Review** — Performing a quick visual check may reveal many problems, such as connectors not properly seated or loose cables. Check the module, the frame, and any associated peripheral equipment for signs of trouble.
2. **Power Check** — Check the power indicator LED on the distribution frame front panel for the presence of power. If the power LED is not illuminated, verify that the power cable is connected to a power source and that power is available at the power main. Confirm that the power supplies are fully seated in their slots. If the power LED is still not illuminated, replace the power supply with one that is verified to work.
3. **Reseat the Card in the Frame** — Eject the card and reinsert it in the frame.
4. **Check Control Settings** — Refer to the Installation and Operation sections of the manual and verify all user-adjustable component settings.
5. **Input Signal Status** — Verify that source equipment is operating correctly and that a valid signal is being supplied.
6. **Output Signal Path** — Verify that destination equipment is operating correctly and receiving a valid signal.
7. **Module Exchange** — Exchanging a suspect module with a module that is known to be working correctly is an efficient method for localizing problems to individual modules.

---

## Warranty and Repair Policy

The openGear™ card is warranted to be free of any defect with respect to performance, quality, reliability, and workmanship for a period of FIVE (5) years from the date of shipment from our factory. In the event that your Cobalt Digital Inc. card proves to be defective in any way during this warranty period, Cobalt Digital Inc. reserves the right to repair or replace this piece of equipment with a unit of equal or superior performance characteristics.

Should you find that this openGear™ card has failed after your warranty period has expired, we will repair your defective product should suitable replacement components be available. You, the owner, will bear any labor and/or part costs incurred in the repair or refurbishment of said equipment beyond the FIVE (5) year warranty period.

In no event shall Cobalt Digital Inc. be liable for direct, indirect, special, incidental, or consequential damages (including loss of profits) incurred by the use of this product. Implied warranties are expressly limited to the duration of this warranty.

This openGear™ card Owner's Manual provides all pertinent information for the safe installation and operation of your Cobalt Digital Inc. Product. Cobalt Digital Inc. policy dictates that all repairs to the openGear™ card are to be conducted only by an authorized Cobalt Digital Inc. factory representative. Therefore, any unauthorized attempt to repair this product, by anyone other than an authorized Cobalt Digital Inc. factory representative, will automatically void the warranty. Please contact Cobalt Digital Inc. Technical Support for more information.

### ***In Case of Problems***

Should any problem arise with your openGear™ card, please contact the Cobalt Digital Inc. Technical Support Department. (Contact information is supplied at the end of this publication.)

A Return Material Authorization number (RMA) will be issued to you, as well as specific shipping instructions, should you wish our factory to repair your openGear™ card. If required, a temporary replacement module will be made available at a nominal charge. Any shipping costs incurred will be the responsibility of you, the customer. All products shipped to you from Cobalt Digital Inc. will be shipped collect.

The Cobalt Digital Inc. Technical Support Department will continue to provide advice on any product manufactured by Cobalt Digital Inc., beyond the warranty period without charge, for the life of the equipment.

# Ordering Information

---

## 9003 and Related Products

Your **9003 Dual HD/SD Reclocking Distribution Amplifier** is a part of the openGear™ family of products. Cobalt Digital offers a full line of openGear™ terminal equipment including distribution, conversion, monitoring, synchronizers, encoders, decoders, embedders, and de-embedders, as well as analog audio and video products.

### ***Standard Equipment***

- **9003** Dual HD/SD Reclocking Distribution Amplifier
- **9003-OM** Dual HD/SD Reclocking Distribution Amplifier Owner's Manual

### ***Optional Equipment***

- **9003-OM** Dual HD/SD Reclocking Distribution Amplifier Owner's Manual (additional Owner's Manual)
- **RM-9003-A** openGear™ Rear Module compatible with 9003 (10 BNC connector)
- **8310-C** Digital Products Frame and Power Supply with Cooling Fans (2RU, holds 10 cards)
- **8310-C-BNC** Digital Products Frame and Power Supply with fixed 100-BNC Rear Module and Cooling Fans. (2RU, holds 10 cards)
- **MFC-8310-N** Network Controller Card (Additional)

# Contact Us

---

## Contact Cobalt Digital Inc.

<b>PHONE</b>	<b>General Business Office and Technical Support</b>	217.344.1243
	<b>Fax</b>	217.344.1245
<b>E-MAIL</b>	<b>General Information</b>	Info@cobaltdigital.com
	<b>Sales Information</b>	Sales@cobaltdigital.com
<b>POSTAL SERVICE</b>	<b>Cobalt Digital Inc.</b>	2406 East University Avenue Urbana, IL 61802 USA

---

## Visit us at the Cobalt Digital Inc. website.

*<http://www.cobaltdigital.com>*

- Online catalog
- Related products and full product lines
- Trade show information
- Dealer information
- Cobalt Digital Inc. news