

9011

**Standard Definition
Digital to Analog Converter
10-bit SDI to
Analog Composite, Y/C,
RGB and Component**

Owner's Manual



9011-OM
Version: 1.0



9011 • Standard Definition D/A 10-bit SDI to Analog Composite, Y/C, RGB and Component Owner's Manual

- Cobalt Part Number: **9011-OM**
- Document Version: **1.0**
- Printed in the United States.
- Last Author: KGM
- Printing Date: 04/01/08 9:44 AM

The information contained in this Owner's Manual is subject to change without notice or obligation.

Copyright



© 2008 Cobalt Digital Inc. All rights reserved.

Contents of this publication may not be reproduced in any form without the written permission of Cobalt Digital Inc. Reproduction or reverse engineering of copyrighted software is prohibited.

Notice

The material in this manual is furnished for informational use only. It is subject to change without notice and should not be construed as a commitment by Cobalt Digital Inc. Cobalt Digital Inc assumes no responsibility or liability for errors or inaccuracies that may appear in this manual.

Trademarks

-  is a registered trademark of Ross Video Limited.
-  is a registered trademark of Cobalt Digital Inc.
- All other product names and any registered and unregistered trademarks mentioned in this manual are used for identification purposes only and remain the exclusive property of their respective owners.

Important Regulatory and Safety Notices

Before using this product and any associated equipment, refer to the “Important Safety Instructions” listed below so as to avoid personnel injury and to prevent product damage.

Products may require specific equipment, and /or installation procedures be carried out to satisfy certain regulatory compliance requirements. Notices have been included in this publication to call attention to these specific requirements.

Symbol Meanings



This symbol on the equipment refers you to important operating and maintenance (servicing) instructions within the Product Manual Documentation. Failure to heed this information may present a major risk of damage or injury to persons or equipment.



Warning

The symbol with the word “**Warning**” within the equipment manual indicates a potentially hazardous situation, which if not avoided, could result in death or serious injury.



Caution

The symbol with the word “**Caution**” within the equipment manual indicates a potentially hazardous situation, which if not avoided, may result in minor or moderate injury. It may also be used to alert against unsafe practices.



Notice

The symbol with the word “**Notice**” within the equipment manual indicates a situation, which if not avoided, may result in major or minor equipment damage or a situation which could place the equipment in a non-compliant operating state.



ESD

Susceptibility

This symbol is used to alert the user that an electrical or electronic device or assembly is susceptible to damage from an ESD event.

Important Safety Instructions



Caution

This product is intended to be a component product of the openGear™ frame. Refer to the openGear™ frame Owner’s Manual for important safety instructions regarding the proper installation and safe operation of the frame as well as it’s component products.



Warning

Certain parts of this equipment namely the power supply area still present a safety hazard, with the power switch in the OFF position. To avoid electrical shock, disconnect all A/C power cords from the chassis' rear appliance connectors before servicing this area.



Warning

Service barriers within this product are intended to protect the operator and service personnel from hazardous voltages. For continued safety, replace all barriers after any servicing.

This product contains safety critical parts, which if incorrectly replaced may present a risk of fire or electrical shock. Components contained within the product’s power supplies and power supply area, are not intended to be customer serviced and should be returned to the factory for repair.

To reduce the risk of fire, replacement fuses must be the same type and rating. Only use attachments/accessories specified by the manufacturer.

Environmental Information

The equipment that you purchased required the extraction and use of natural resources for its production. It may contain hazardous substances that could impact health and the environment.

To avoid the potential release of those substances into the environment and to diminish the need for the extraction of natural resources, Cobalt Digital encourages you to use the appropriate take-back systems. These systems will reuse or recycle most of the materials from your end-of-life equipment in an environmentally friendly and health conscious manner.

The crossed-out wheeled bin symbol invites you to use these systems.

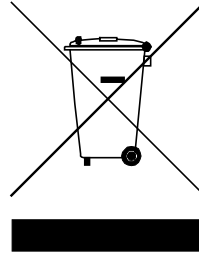

If you need more information on the collection, reuse, and recycling systems, please contact your local or regional waste administration.

You can also contact Cobalt Digital for more information on the environmental performances of our products.

Contents

Introduction	6
In This Chapter.....	6
A Word of Thanks.....	6
Overview.....	6
Features.....	7
Color Framing.....	7
Software Version.....	7
Functional Block Diagram.....	8
Supported Audio and Video Formats.....	8
Input and Output Video.....	8
Documentation Terms.....	9
Installation and Setup	10
In This Chapter.....	10
Static Discharge.....	10
Unpacking.....	10
Rear Module Installation (Optional).....	11
Rear Module Available for 9011.....	12
Board Installation.....	13
Card Control and Status.....	14
Card Control Switches.....	14
Card Status LEDs.....	15
Reference Configuration and Termination.....	15
Factory Default Settings.....	15
Remote Control	16
In This Chapter.....	16
DashBoard Control System Software.....	16
Technical Specifications	17
Service Information	18
In This Chapter.....	18
Troubleshooting Checklist.....	18
Warranty and Repair Policy.....	19
Ordering Information	20
9011 and Related Products.....	20
Notes:.....	21
Contact Us	22
Contact Cobalt Digital Inc.....	22
Visit us at the Cobalt Digital Inc. website.....	22

Introduction

In This Chapter

This chapter includes the following sections:

- A Word of Thanks
- Overview
- Functional Block Diagram
- Supported Video Formats
- Documentation Terms

A Word of Thanks

Congratulations on choosing the openGear™ **9011 Standard Definition D/A 10-bit SDI to Analog Composite, Y/C, RGB and Component**. The 9011 is part of a full line of modular conversion gear for broadcast TV environments. The Cobalt Digital openGear™ line includes video decoders and encoders, audio embedders and de-embedders, distribution amplifiers, format converters, and much more. Cobalt openGear™ modular conversion gear will meet your signal conversion needs now and well into the future.

Should you have questions pertaining to the installation or operation of your 9011, please contact us at the numbers listed on the back cover of this manual. We are happy to help with any questions regarding this or any other openGear™ card.

Overview

The 9011 is a high quality standard definition digital to analog converter for converting 525/625 4:2:2 SDI signals to analog Composite, Y/C and Component signals (YPbPr or RGB). The 9011 auto-detects the line input standard and outputs the corresponding NTSC or PAL standard. The user can configure the default PAL outputs to be PAL-B/D/G/H/I, PAL N or PAL 60 and NSTC M or N. Pedestal selection can be enabled or disabled for NTSC operation.

The 9011 can be externally configured to three different analog output configurations: all Composite, dual Composite with Y/C or Composite with Component. The 9011 supports four different Component output modes: BetaCam™, MII™, SMPTE/N10 and RGB. The encoding process is 10-bit with sample up-conversion from 4:2:2 to 8:8:8 (2x output mode) or 16:16:16 (4x output mode). Full user digital processing (proc.) controls are available to the end user for adjusting black level, Y Gain,

Saturation and Hue. Advanced controls include VBI Blanking, line by line VBI Pedestal control, extended filtering, DNR and Gamma configuration. All adjustments can be saved to non-volatile memory or Factory defaults can be restored. A De-jitter VCXO is included to reduce input jitter from high frequencies down to 2Hz.

The 9011 has four reclocked digital output copies of the input SDI signal or three when the Genlock input is used, and one BNC reserved for Black Burst input. The user must adjust the SDI source's H-Phase for horizontal sync alignment. A full 360 degrees of SCH phase is user adjustable on the 9011.

The input and outputs of the 9011 are the following:

Inputs:

- One 10-bit SD-SDI video input
- One black burst reference input for color framing purposes

Outputs:

- Four reclocked SD-SDI video outputs
- Four analog SD video outputs

Features

Color Framing

Although an SD-SDI signal carries more information than a composite signal, it does not properly encode the SCH (Sub-Carrier to Horizontal) phase of the original composite signal. SCH phase is a measure of the relationship of the start of the color burst to the start of the horizontal sync. In NTSC each field has an SCH phase of 90° more than the previous field, thus the SCH sequence repeats every four fields. Since each SDI field encodes the field type (odd or even) but not the SCH phase, a given video encoder cannot recreate the SCH phase without a reference signal. This creates problems when trying to align the signals to the inputs of some sort of switching device that relies on the color phase being unified across channels.

The 9011 gets around this problem by accepting reference on either of the two frame inputs, or on a dedicated BNC on the rear IO module. When reference is detected, the card will automatically ensure that the SCH phase of the output matches that of the reference signal. The reference must be synchronous with the input video for this to work, due to the nature of the comparison.

There is a control to adjust the offset between output SCH phase and detected reference SCH phase. It is not needed in most applications.

Software Version

- This manual is written for software release number 1.0.
- To view the current software release number of your 9011 check the card info menu in Dashboard.
- To upgrade your 9011 software, go to the download page at www.cobaltdigital.com to download the latest release, and upload the file through Dashboard™ (see Dashboard™ user manual, 3-5).

Functional Block Diagram

This section diagrams the basic signal flow of your 9011 product.

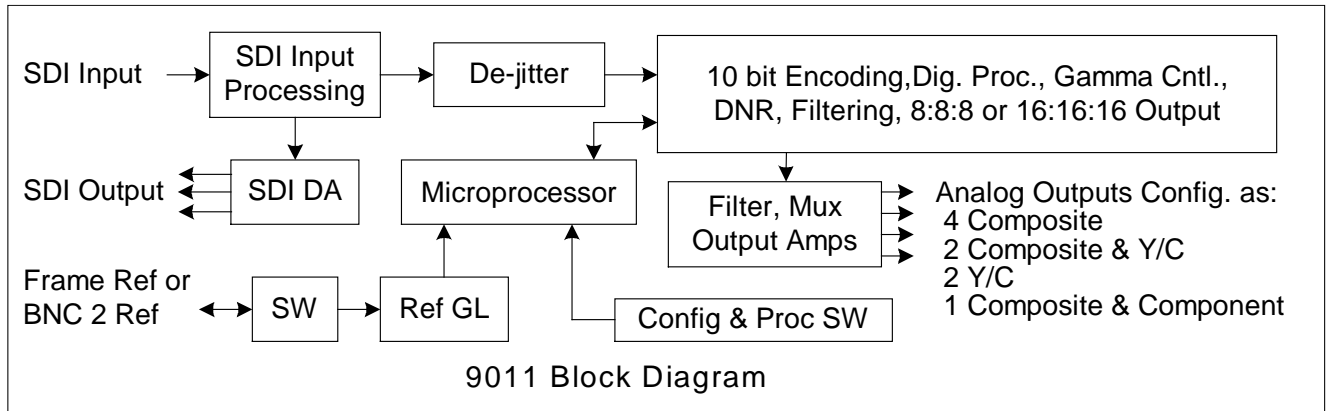

Figure 1. Simplified Block Diagram of 9011 Functions

Supported Audio and Video Formats

Input and Output Video

The 9011 supports both NTSC and PAL formats.

Raster structure	Frame Rate
486i ¹	29.97
575i ¹	25

Notes:

1. All rates displayed as frame rates, interlaced (“i”) field rates are two times the number shown.

Documentation Terms

The following terms are used throughout this guide:

- “**Frame**” refers to the **8310** frame that houses the **9011** card.
- “**Operator**” and “**User**” both refer to the person who uses the **9011**.
- “**Board**” and “**Card**” all refer to the **9011** card itself, including all components and switches.
- “**System**” and “**Video system**” refers to the mix of interconnected production and terminal equipment in which the **9011** operates.

Installation and Setup

In This Chapter

This chapter includes the following sections:

- Static Discharge
- Unpacking
- Rear Module Installation (Optional)
- Board Installation
- BNC Connections
- Menu Structure
- Factory Defaults

Static Discharge

Whenever handling the card and other related equipment, please observe all static discharge precautions as described in the following note:



**ESD
Susceptibility**

Static discharge can cause serious damage to sensitive semiconductor devices. Avoid handling circuit boards in high static environments such as carpeted areas, and when wearing synthetic fiber clothing. Always exercise proper grounding precautions when working on circuit boards and related equipment.

Unpacking

Unpack each card you received from the shipping container, and check the contents against the packing list to ensure that all items are included. If any items are missing or damaged, contact your sales representative or Cobalt Digital directly.

Rear Module Installation (Optional)

If you are installing the card in a 8310-C-BNC or 8310-BNC frame (one with a 100 BNC rear module installed across the entire back plane), skip this section.

If you are installing the card into a slot with no rear module, you should have ordered and received the RM-9011-A module. You will need to install it in your 8310 frame before you can connect cables.

Use the following steps to install a rear module in an 8310 openGear™ frame:

1. Refer to the openGear™ 8310 frame Owner's Manual, to ensure that the frame is properly installed according to instructions.
2. On the rear of the 8310, locate the card frame slot.
3. As shown in Figure 2, seat the bottom of the rear module in the seating slot at the base of the frame's back plane.

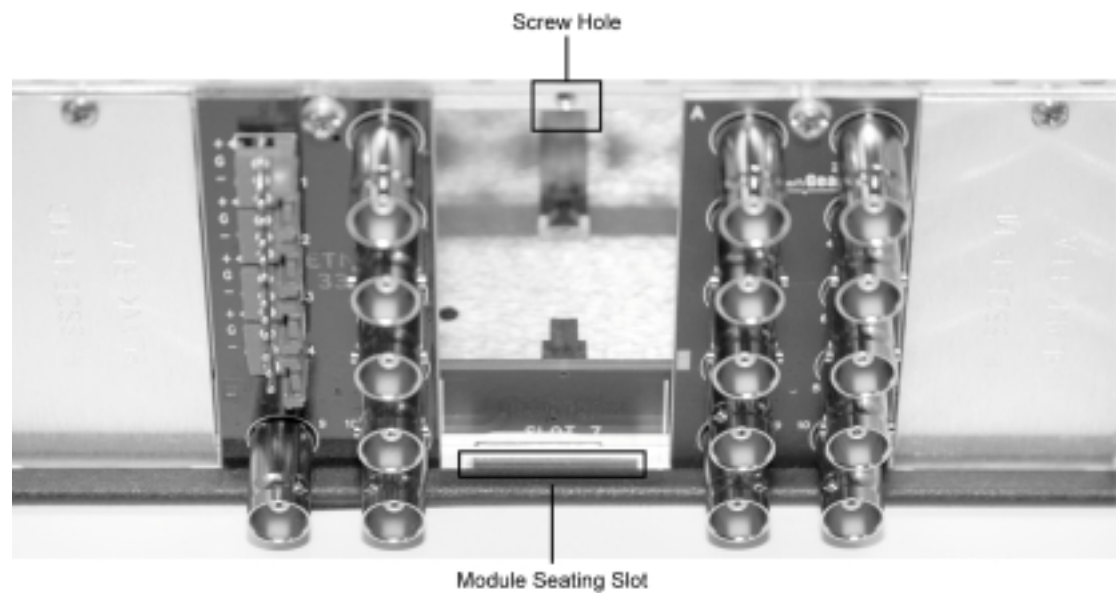

Figure 2. Rear Module Installation

4. Align the top hole of the rear module with the screw hole on the top edge of the 8310 back plane.
5. Using a Phillips driver and the supplied screw, fasten the rear module to the 8310 back plane. Do not over tighten.

All modules are installed using the same method above.

The following section contains a drawing of the RM-9011-A module.

Rear Module Available for 9011

Figure 3. BNC Designations for the Card Rear Module available for the 9011.

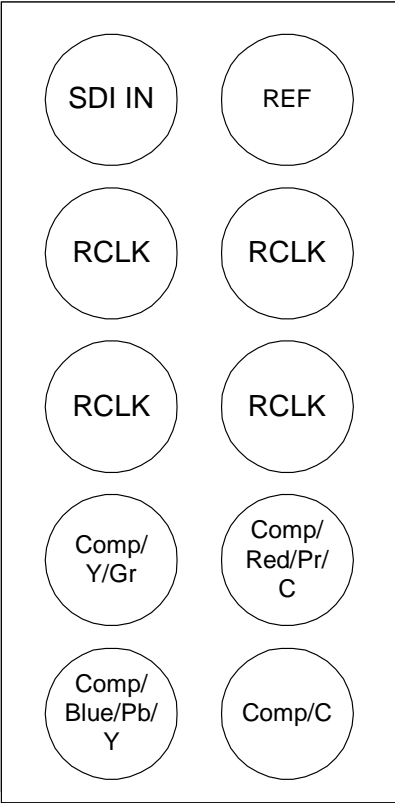

RM-9011-A

Board Installation

Use the following steps to install the card in the openGear™ 8310 frame:

1. Refer to the Owner's Manual of the openGear™ 8310 frame to ensure that the frame is properly installed according to instructions.



Warning

Heat and power distribution requirements within a frame may dictate specific slot placement of cards. Cards with many heat-producing components should be arranged to avoid areas of excess heat build-up, particularly in frames using convection cooling.

2. After selecting the desired frame installation slot, hold the card by the edges and carefully align the card edges with the slots in the frame. Then, fully insert the card into the frame until the rear connection plugs are properly seated on the midplane and rear modules.
3. Connect the input and output cables according to the diagram for the rear module being used. The inputs are internally terminated with 75 Ohms. It is not necessary to terminate unused outputs.

This completes the procedure for installing the card in the openGear™ 8310 frame.

Card Control and Status

Card Control Switches

The majority of the card control can be performed by the 8 switches on switch bank S1. Their operation is detailed in the following table.

S1.1	S1.2	S1.3	VIDEO INPUT AND COLOR SEPARATION MODE
ON*	ON*	ON*	All Composite
ON	OFF	ON	BNC 7 – Y, BNC 8 – C, BNC 9 – Composite, BNC 10 – Composite
ON	OFF	OFF	BNC 7 – Y, BNC 8 – C, BNC 9 – Y, BNC 10 – C
OFF	ON	ON	BETACAM™ BNC 7 – Y, BNC 8 – Pr, BNC 9 – Pb, BNC 10 – Composite
OFF	ON	OFF	MIITM BNC 7 – Y, BNC 8 – Pr, BNC 9 – Pb, BNC 10 – Composite
OFF	OFF	ON	SMPTE BNC 7 – Y, BNC 8 – Pr, BNC 9 – Pb, BNC 10 – Composite
OFF	OFF	OFF	RGB BNC 7 – Y, BNC 8 – Pr, BNC 9 – Pb, BNC 10 – Composite
S1.4			OUTPUT COLOR ENABLE
ON*			Enable color on output
OFF			Disable color on output
S1.5			OUTPUT TEST PATTERN
ON			Enable 75% color bars as output pattern, regardless of input signal
OFF*			Disable output test pattern
S1.6			ENABLE SETUP/PEDESTAL ON NTSC OUTPUT
ON*			Output signal with 7.5 IRE setup/pedestal
OFF			Output signal with 0 IRE of pedestal
S1.7			ENABLE OUTPUT OVERSAMPLING
ON*			Output DAC runs at 2x SDI Y channel data rate (8:8:8 sampling)
OFF			Output DAC runs at 4x SDI Y channel data rate (16:16:16 sampling)
S1.8			ENABLE OUTPUT DEJITTER FILTER
ON*			DAC clock de-jitter filter enabled
OFF			DAC clock de-jitter filter disabled

Other, less used, parameters are adjusted by dialing S3 and S4 to certain values, and then moving the thumb switch S2 up or down. These parameters are detailed in the following table. For any given parameters, pressing the REGISTER RESTORE button (S5) will restore the parameter to its saved setting.

S3	S4	Internal Parameter
0	0	Normal card operation
1	1	Y Gain
1	2	Y Offset (Black level)
1	3	Color Saturation
1	4	Hue (for Composite and Y/C outputs only) +/-22.5° in 0.18° increments
1	5	SCH Phase
1	6	Sharpness -4dB to +4dB in 12 steps
2	7	VBI lines 10-20 Encoded (LED On = Encoded, Off = VBI Blanked)
5	0	Add setup/pedestal to odd lines 10-18 (NTSC only)
5	1	Add setup/pedestal to odd lines 19-25 (NTSC only)
5	2	Add setup/pedestal to even lines 10-18 (NTSC only)
5	3	Add setup/pedestal to even lines 19-25 (NTSC only)
5	4	Add setup/pedestal to all lines 10-25 (Note: overwrites settings of 5-0 through 5-3)
8	8	Restore Factory Defaults (Press S2 Up)
9	9	Save Settings (Press S2 Up)

Card Status LEDs

The card LEDs report the lock status of the device. See the table below for an explanation of each function.

LED NAME	DESCRIPTION
LOCK LED	Flashes green when not locked to input signal. When locked illuminates steady green. When S3 or S4 not at 0, indicates state of parameter.
NTSC LED	On when locked to NTSC input, off otherwise
PAL LED	On when locked to PAL input, off otherwise
RMT LED	reserved for future use

Reference Configuration and Termination

The 9011 can use either a reference connected to the openGear™ frame, or a reference connected directly to BNC 2 to align the SCH phase of the output video. To use BNC 2 as the reference, set S12 to BNC-2. To use the openGear™ frame's reference, set S12 to FRAME and then select which of the two frame references to be used using S11. It is important to note that the 9011 does not operate as a frame synchronizer. The output video timing will always match the SDI input timing.

Factory Default Settings

The factory default settings are as follows

- 1) S1.1-3 Output is composite on all ports
- 2) S1.4 - Color is On
- 3) S1.5 – Test Pattern is Off
- 4) S1.6 – Setup is On
- 5) S1.7 – Output Sample Mode is 16:16:16
- 6) S1.8 – De-Jitter Filter is On

Remote Control

In This Chapter

This section provides a detailed explanation on using remote control functions with your card.

DashBoard Control System Software

The DashBoard Control System enables you to monitor and control openGear™ frames and controller cards from a computer. The DashBoard software and manual can be downloaded from the Cobalt Digital Inc. website (www.cobaltdigital.com).

Using the Menus and Menu Descriptions

You must first install the DashBoard Control System software on your computer. Refer to the *DashBoard User Manual* for software installation procedures and for using the DashBoard interface.

The following pages list the parameters from the menu tabs available in the DashBoard software when connected to a 9011.

Menu	Item	Format	Description
Card Info (Read-only)	Product	CDI-9011	The product name
	Manufacturer	Cobalt Digital Inc.	The manufacturer of the product
	Serial Number	#####	The product serial number
	Software Release Number	###	The release number of the firmware in this card
	PIC Software Build Number	##	The internal build number of this software
	Temperature	Degrees C / Degrees F	The surface temp of the board
	+12 V Power Rail	### W	Positive Supply Power
	-7.5 Power Rail	### W	Negative Supply Power
	Power	## W	Total power consumed by the board
	Input Signal	#####	Detected standard of the input signal.

Technical Specifications

Table 4. Card - Technical Specifications

Category	Parameter	Specification
Serial Digital Video Input	Data Rates Supported	SMPTE 259M-C SD-SDI: 270 Mbps
	Frame Rates Supported	486i 29.97 NTSC, 575i 25 PAL
	Impedance	75Ω terminating
	Equalization	1000ft (300 meters) Belden 1694A
	Return Loss	>18dB at 5MHz – 270MHz
Analog Video Output	Number of Outputs	4
	Video Outputs	Composite, Component YPbPr (BetaCam™, MII™, SMPTE/N10), RGB, and Y/C
	Conversion Bit Depth	10-Bits
	Frequency Response	4x Y: 0-5.5 MHz +/- 0.15 dB 4x PbPr: 0-2.2 MHz +/-0.25 dB
	Differential Phase	< ±0.5° typical
	Differential Gain	< ±0.5% typical
	S/N	> 75 dB
	Conversion Time	< 2 us
	K-Factor 2T	< 0.6%
	SCH Phase	< 0.8%
	Return Loss	> 35dB to 5 MHz
Reference Video Input	Number of Inputs	1 Terminating Frame Reference Inputs 1 Terminating Reference on BNC 2
	Standards Supported	486i 29.97 NTSC, 575i 25 PAL
	Signal Level	1Vp-p nominal
	Signal	Analog video sync (black burst or tri-level)
	Impedance	75Ω
	Return Loss	> 30dB to 30MHz
	Max DC on Ref Input	±1V
Other	Total Power Consumption	< 7W
	Warranty	Five Year Transferable

Specifications are subject to change without notice.

Service Information

In This Chapter

This chapter includes the following sections:

- Troubleshooting Checklist
- Warranty and Repair Policy

Troubleshooting Checklist

Routine maintenance to this openGear™ product is not required. In the event of problems with your card, the following basic troubleshooting checklist may help identify the source of the problem. If the module still does not appear to be working properly after checking all possible causes, please contact your openGear™ products distributor, or the Technical Support department at the numbers listed under the “Contact Us” section at the end of this manual.

1. **Visual Review** — Performing a quick visual check may reveal many problems, such as connectors not properly seated or loose cables. Check the module, the frame, and any associated peripheral equipment for signs of trouble.
2. **Power Check** — Check the power indicator LED on the distribution frame front panel for the presence of power. If the power LED is not illuminated, verify that the power cable is connected to a power source and that power is available at the power main. Confirm that the power supplies are fully seated in their slots. If the power LED is still not illuminated, replace the power supply with one that is verified to work.
3. **Reseat the Card in the Frame** — Eject the card and reinsert it in the frame.
4. **Check Control Settings** — Refer to the Installation and Operation sections of the manual and verify all user-adjustable component settings.
5. **Input Signal Status** — Verify that source equipment is operating correctly and that a valid signal is being supplied.
6. **Output Signal Path** — Verify that destination equipment is operating correctly and receiving a valid signal.
7. **Module Exchange** — Exchanging a suspect module with a module that is known to be working correctly is an efficient method for localizing problems to individual modules.

Warranty and Repair Policy

The openGear™ card is warranted to be free of any defect with respect to performance, quality, reliability, and workmanship for a period of FIVE (5) years from the date of shipment from our factory. In the event that your Cobalt Digital Inc. card proves to be defective in any way during this warranty period, Cobalt Digital Inc. reserves the right to repair or replace this piece of equipment with a unit of equal or superior performance characteristics.

Should you find that this openGear™ card has failed after your warranty period has expired, we will repair your defective product should suitable replacement components be available. You, the owner, will bear any labor and/or part costs incurred in the repair or refurbishment of said equipment beyond the FIVE (5) year warranty period.

In no event shall Cobalt Digital Inc. be liable for direct, indirect, special, incidental, or consequential damages (including loss of profits) incurred by the use of this product. Implied warranties are expressly limited to the duration of this warranty.

This openGear™ card Owner's Manual provides all pertinent information for the safe installation and operation of your Cobalt Digital Inc. Product. Cobalt Digital Inc. policy dictates that all repairs to the openGear™ card are to be conducted only by an authorized Cobalt Digital Inc. factory representative. Therefore, any unauthorized attempt to repair this product, by anyone other than an authorized Cobalt Digital Inc. factory representative, will automatically void the warranty. Please contact Cobalt Digital Inc. Technical Support for more information.

In Case of Problems

Should any problem arise with your openGear™ card, please contact the Cobalt Digital Inc. Technical Support Department. (Contact information is supplied at the end of this publication.)

A Return Material Authorization number (RMA) will be issued to you, as well as specific shipping instructions, should you wish our factory to repair your openGear™ card. If required, a temporary replacement module will be made available at a nominal charge. Any shipping costs incurred will be the responsibility of you, the customer. All products shipped to you from Cobalt Digital Inc. will be shipped collect.

The Cobalt Digital Inc. Technical Support Department will continue to provide advice on any product manufactured by Cobalt Digital Inc., beyond the warranty period without charge, for the life of the equipment.

Ordering Information

9011 and Related Products

Your **9011 Standard Definition D/A 10-bit SDI to Analog Composite, Y/C, RGB and Component** is a part of the openGear™ family of products. Cobalt Digital offers a full line of openGear™ terminal equipment including distribution, conversion, monitoring, synchronizers, encoders, decoders, embedders, and de-embedders, as well as analog audio and video products.

Standard Equipment

- **9011** Standard Definition D/A 10-bit SDI to Analog Composite, Y/C, RGB and Component
- **9011-OM** Standard Definition D/A 10-bit SDI to Analog Composite, Y/C, RGB and Component Owner's Manual

Optional Equipment

- **9011-OM** Standard Definition D/A 10-bit SDI to Analog Composite, Y/C, RGB and Component Owner's Manual (additional Owner's Manual)
- **RM-9011-A** openGear™ Rear Module compatible with 9011 (10 BNC connector)
- **8310-C** Digital Products Frame and Power Supply with Cooling Fans (2RU, holds 10 cards)
- **8310-C-BNC** Digital Products Frame and Power Supply with fixed 100-BNC Rear Module and Cooling Fans. (2RU, holds 10 cards)
- **MFC-8310-N** Network Controller Card (Additional)

Notes:

Contact Us

Contact Cobalt Digital Inc.

PHONE	General Business Office and Technical Support	217.344.1243
	Fax	217.344.1245
E-MAIL	General Information	Info@cobaltdigital.com
	Sales Information	Sales@cobaltdigital.com
POSTAL SERVICE	Cobalt Digital Inc.	2406 East University Avenue Urbana, IL 61802 USA

Visit us at the Cobalt Digital Inc. website.

<http://www.cobaltdigital.com>

- Online catalog
- Related products and full product lines
- Trade show information
- Dealer information
- Cobalt Digital Inc. news