

---

**F3G  
FUSION**

**Option** 



**Dolby<sup>®</sup> Decoder Option (+DEC)**

# ***Manual Supplement***

---



**Cobalt Digital Inc.**

2406 E. University Ave.  
Urbana, IL 61802  
Voice 217.344.1243 • Fax 217.344.1245  
[www.cobaltdigital.com](http://www.cobaltdigital.com)

---

## Copyright

©Copyright 2011, Cobalt Digital Inc. All Rights Reserved.

Duplication or distribution of this manual and any information contained within is strictly prohibited without the express written permission of Cobalt Digital Inc. This manual and any information contained within, may not be reproduced, distributed, or transmitted in any form, or by any means, for any purpose, without the express written permission of Cobalt Digital Inc. Reproduction or reverse engineering of software used in this device is prohibited.

## Disclaimer

The information in this document has been carefully examined and is believed to be entirely reliable. However, no responsibility is assumed for inaccuracies. Furthermore, Cobalt Digital Inc. reserves the right to make changes to any products herein to improve readability, function, or design. Cobalt Digital Inc. does not assume any liability arising out of the application or use of any product or circuit described herein. **This manual is a supplement and is incomplete unless used with an Owner's or Product Manual. Refer to the applicable Product Manual for complete personnel protection and equipment safety information.**

## Trademark Information

**Cobalt**<sup>®</sup> is a registered trademark of Cobalt Digital Inc.

**FUSION3G**<sup>®</sup> is a registered trademark of Cobalt Digital Inc. **COMPASS**<sup>™</sup> is a trademark of Cobalt Digital Inc.

**openGear**<sup>®</sup> is a registered trademark of Ross Video Limited. **DashBoard**<sup>™</sup> is a trademark of Ross Video Limited. Dolby<sup>®</sup> encoder technology on this card is manufactured under license from Dolby Laboratories. **Dolby**<sup>®</sup> is a registered trademark of Dolby Laboratories, Inc. Other product names or trademarks appearing in this manual are the property of their respective owners.

**Linear Acoustic**<sup>®</sup> is a registered trademark of Linear Acoustic Inc. 2.0-to-5.1 audio upmixer licensed feature uses the **AutoMAX-II**<sup>™</sup> upmix algorithm provided under license from Linear Acoustic Inc. Loudness processor licensed feature uses **AEROMAX**<sup>™</sup> algorithms provided under license from Linear Acoustic Inc. **Linear Acoustic**, the "LA" symbol, **UPMAX**, **AutoMAX**, **AutoMAX-II**, and **AEROMAX** are trademarks of Linear Acoustic Inc. All Rights Reserved.

<b>Manual No.:</b>	OPT-SW-F3GDEC-MS
<b>Document</b>	
<b>Version:</b>	1.1
<b>Release Date:</b>	June 27, 2011

## Overview

This manual supplement provides descriptions and operating instruction for the **+DEC** (Dolby® Decode) Option available as a factory-installed option on new Cobalt® FUSION3G® (9900-Series) cards.

## +DEC (Dolby Decode) Option Functional Description

(See Figure 1.) When Dolby® E or Dolby® Digital™ is present on a discrete AES pair or a de-embedded audio pair from either program video stream, the decoder can produce up to 10 decoded channels (according to the Dolby® sub-format received from the metadata). All resulting channels are available as inputs to the input routing/mixing function.

**Dolby® Identification and Metadata Output Processing.** (See Figure 1.) All AES pairs and embedded channels are checked by the card for valid Dolby® status. When a valid Dolby® encoded embedded or discrete AES pair is detected, the channel pair carrying the Dolby® format is displayed as “Dolby E” or “Dolby Digital”, as applicable. (The decoder always uses the metadata associated with its respective AES or embedded pair.) A selected encoded channel pair can then be directed to the Dolby® decoder. The decoder then displays the Dolby® bitstream format and program configuration (for example, “Dolby E 20-bit 5.1+2” indicating 5-channel surround with LFE channel and stereo monitor pair) for the selected pair, as defined by its metadata.

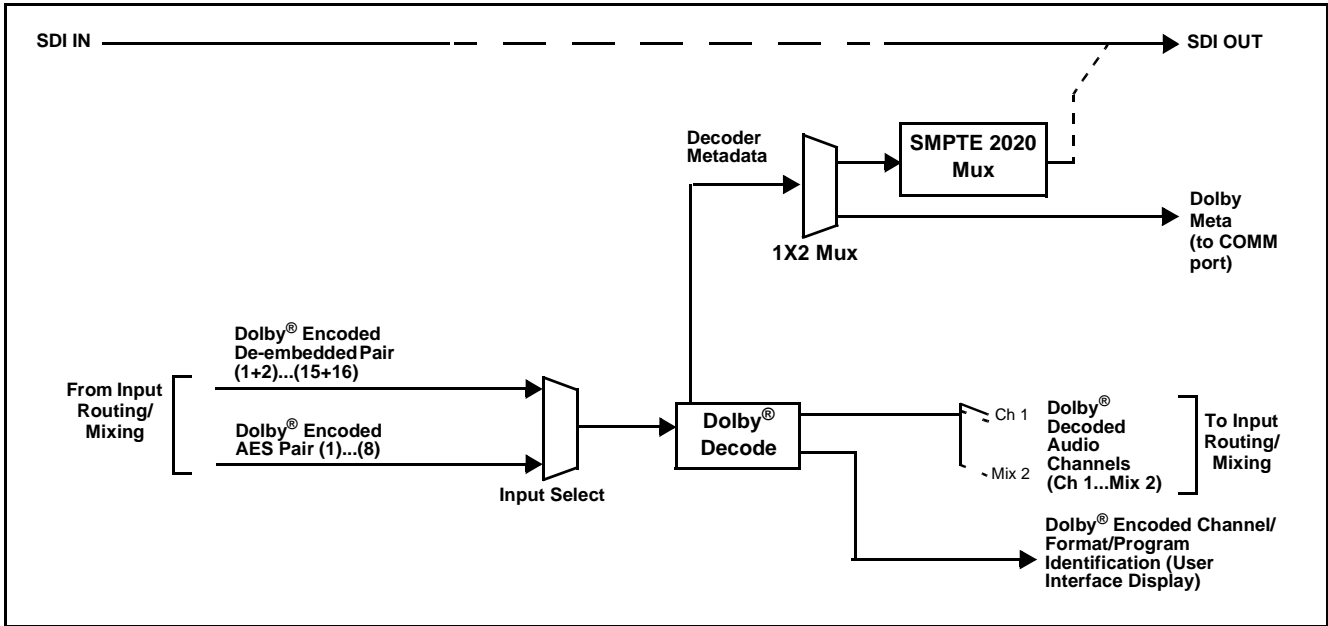

**Figure 1 Dolby® Decoding and Metadata Output Processing**

The card can embed metadata on the SDI output, sourced from either SDI input video or from the decoder as desired. Similarly, the **Dolby Meta** output can provide metadata for downstream devices or systems via a **COMM** port on the card. Metadata on the **Dolby Meta** output can also be sourced from either SDI input video or from the decoder as desired.

**Audio Decoding.** (See Figure 1.) Based on the channels carrying the Dolby® encoded pair and the format defined within, the Dolby® decoder provides up to 10 decoded audio channels (**Dolby Ch 1** thru **Dolby Ch 8**; **Dolby Mix 1**, **Dolby Mix 2**). Each channel can be routed or downmixed just as any other audio channel handled by the input routing/mixing function.

# Dolby Decoder Controls and Examples

Table 1 individually lists and describes Dolby decoder controls available using DashBoard™ for cards equipped with the +DEC option.

**Table 1 +DEC Option Control List and Descriptions**

Dolby Decoder

Routes a Dolby® encoded AES pair or embedded audio source to the Dolby® decoder, and provides Dolby® configuration display and metadata displays.

General

Dolby D Metadata

Dolby E Metadata

**Note:** Decoded channels shown in DashBoard™ correlate to typical channel designations as shown below. Note that channel designations are a function of encoding. Based on encoding, actual channel designations may vary from the examples shown here.

Decoder Output Channels	E5.1+2	E7.1+2	E8x1
Ch 1	LF	LF	Ch 1
Ch 2	RF	RF	Ch 2
Ch 3	C	C	Ch 3
Ch 4	LFE	LFE	Ch 4
Ch 5	LS	LS	Ch 5
Ch 6	RS	RS	Ch 6
Ch 7	Aux 1	LB	Ch 7
Ch 8	Aux 2	RB	Ch 8
Mix L	Lo	Lo	Mono Mix 1
Mix R	Ro	Ro	Mono Mix 2



  

Decoder Output Channel	D1/0	D2/0	D3/0	D2/1	D3/1	D2/2	D3/2
Ch 1	—	L	L	L	L	L	L
Ch 2	—	R	R	R	R	R	R
Ch 3	C	—	C	—	C	—	C
Ch 4	—	—	—	—	—	—	—
Ch 5	—	—	—	S	S	LS	LS
Ch 6	—	—	—	—	—	RS	RS

  

Decoder Output Channel	D3/0L		D2/1L		D3/1L		D2/2L		D3/2L	
Ch 1	L	L	L	L	L	L	L	L	L	L
Ch 2	R	R	R	R	R	R	R	R	R	R
Ch 3	C	—	C	—	C	—	C	—	C	C
Ch 4	LFE	LFE	LFE	LFE	LFE	LFE	LFE	LFE	LFE	LFE
Ch 5	—	S	S	S	S	LS	LS	LS	LS	LS
Ch 6	—	—	—	—	—	RS	RS	RS	RS	RS

**Table 1 +DEC Option Control List and Descriptions — continued**

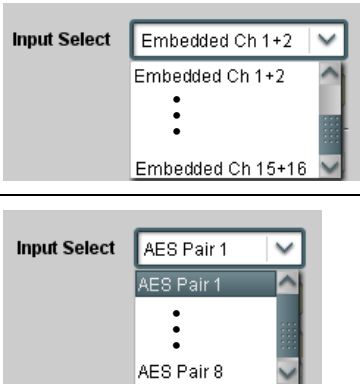
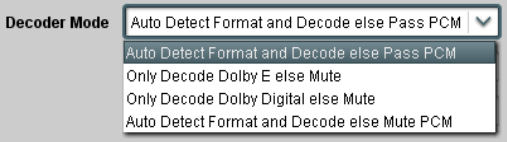
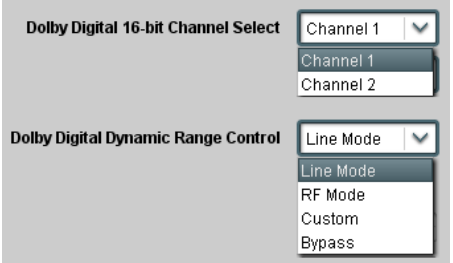
	<p>(continued)</p>
<p><b>• Bitstream Info and Status Display</b></p> 	<p>Displays encoding status as follows:</p> <ul style="list-style-type: none"> <li>• <b>Info</b> shows selected Dolby mode and audio coding, as well as actual bitstream rate.</li> <li>• <b>Decoder Errors</b> shows running count of any errors occurring. <b>Reset Status Counts</b> button allows resetting error counts.</li> </ul>
<p><b>• Encoded Input Pair Select</b></p> 	<p>Selects Embedded or AES channel pair carrying encoded data to the decoder.</p> <p><b>Embedded Ch 1+2</b> thru <b>Ch 15+16</b> range in Input Select drop-down list selects an embedded channel pair (1+2 thru 15+16) to be the input for the Dolby® decoder.</p> <p>(In this example, embedded channel pair 1+2 is the input for the Dolby® decoder)</p> <p><b>AES Pair 1</b> thru <b>AES Pair 8</b> range in Input Select drop-down list selects an AES Pair (1 thru 8) to be the input for the Dolby® decoder.</p> <p>(In this example, AES Pair 1 is the input for the Dolby® decoder)</p>
<p><b>• Decoder Mode</b></p> 	<p>Using the drop-down list, selects the action to take in presence or absence of Dolby® E or Digital source from the choices shown on the left.</p>
<p><b>• Dolby® Digital Channel and Dynamic Range Controls</b></p> 	<p><b>Channel Select</b> drop-down list sets the channel carrying the Dolby® Digital encoded signal for D1/0 formats as shown from choices on the left.</p> <p><b>Dynamic Range Control</b> drop-down list selects from audio level compression scheme choices as shown to the left. (Line Mode is typical setting; RF Mode is used where signal may be fed through low-cost video/ audio RF modulator, in which case RF Mode helps prevent overmodulation. Refer to ATSC A/52B for more information.)</p>

**Table 1 +DEC Option Control List and Descriptions — continued**

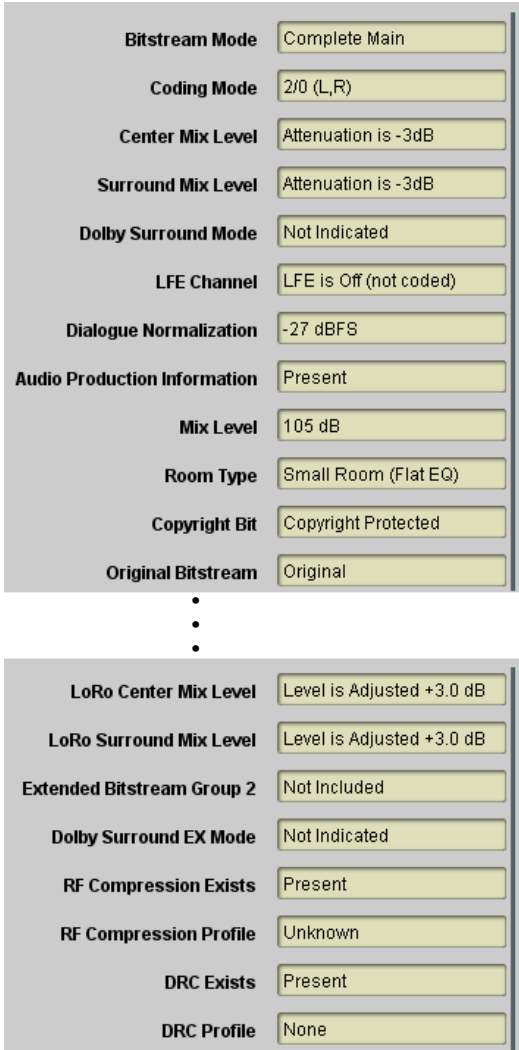
<div style="background-color: #444; color: white; padding: 5px; display: inline-block; border: 1px solid black;">Dolby Decoder</div>	<p>Displays the status and programming details for Dolby® Digital program dictated by the Digital metadata being used.</p>
<div style="display: flex; justify-content: space-around; border: 1px solid black; padding: 2px;"> <span style="background-color: #ccc; padding: 2px 5px;">Dolby D Metadata</span> <span style="background-color: #ccc; padding: 2px 5px;">Dolby E Metadata</span> </div>	
<p><b>Note:</b></p> <ul style="list-style-type: none"> <li>• This display is read-only. No changes can be made to the settings. All displays are reports per the metadata being used.</li> <li>• Information provided here is intended as an overview of the screen. Displayed parameters are per ATSC A/52B definitions. Refer to ATSC A/52B for detailed descriptions and background.</li> </ul>	
 <p>The screenshot shows a list of audio parameters with their corresponding values in a light yellow box:</p> <ul style="list-style-type: none"> <li>Bitstream Mode: Complete Main</li> <li>Coding Mode: 2/0 (L,R)</li> <li>Center Mix Level: Attenuation is -3dB</li> <li>Surround Mix Level: Attenuation is -3dB</li> <li>Dolby Surround Mode: Not Indicated</li> <li>LFE Channel: LFE is Off (not coded)</li> <li>Dialogue Normalization: -27 dBFS</li> <li>Audio Production Information: Present</li> <li>Mix Level: 105 dB</li> <li>Room Type: Small Room (Flat EQ)</li> <li>Copyright Bit: Copyright Protected</li> <li>Original Bitstream: Original</li> <li>LoRo Center Mix Level: Level is Adjusted +3.0 dB</li> <li>LoRo Surround Mix Level: Level is Adjusted +3.0 dB</li> <li>Extended Bitstream Group 2: Not Included</li> <li>Dolby Surround EX Mode: Not Indicated</li> <li>RF Compression Exists: Present</li> <li>RF Compression Profile: Unknown</li> <li>DRC Exists: Present</li> <li>DRC Profile: None</li> </ul>	

**Table 1 +DEC Option Control List and Descriptions — continued**

<b>Dolby Decoder</b>		Displays the status and programming details for Dolby® E program dictated by the Dolby E metadata being used.							
Dolby D Metadata	Dolby E Metadata								
<p><b>Note:</b> • This display is read-only. No changes can be made to the settings. All displays are reports per the metadata being used.</p> <ul style="list-style-type: none"> <li>• Information provided here is intended as an overview of the screen. Displayed parameters are per ATSC A/52B definitions. Refer to ATSC A/52B for detailed descriptions and background.</li> </ul>									
<p>Where AC-3 programs exist for the current metadata coding, the columns show the details for the individual AC-3 programs</p> <p>Where AC-3 programs do not exist for the current metadata coding, the columns are collapsed</p>									
<b>Dolby E AC-3 Metadata</b>	1	2	3	4	5	6	7	8	
Bitstream Mode	Visually Impaired	Hearing Impaired	<input type="checkbox"/>	<input type="checkbox"/>	<input type="checkbox"/>	<input type="checkbox"/>	<input type="checkbox"/>	<input type="checkbox"/>	<input type="checkbox"/>
Coding Mode	3/1 (L,C,R,S)	3/1 (L,C,R,S)	<input type="checkbox"/>	<input type="checkbox"/>	<input type="checkbox"/>	<input type="checkbox"/>	<input type="checkbox"/>	<input type="checkbox"/>	<input type="checkbox"/>
Center Mix Level	-4.5dB	-3dB	<input type="checkbox"/>	<input type="checkbox"/>	<input type="checkbox"/>	<input type="checkbox"/>	<input type="checkbox"/>	<input type="checkbox"/>	<input type="checkbox"/>
Surround Mix Level	-6dB	-3dB	<input type="checkbox"/>	<input type="checkbox"/>	<input type="checkbox"/>	<input type="checkbox"/>	<input type="checkbox"/>	<input type="checkbox"/>	<input type="checkbox"/>
Dolby Surround Mode	Dolby Surround Encoded	Not Indicated	<input type="checkbox"/>	<input type="checkbox"/>	<input type="checkbox"/>	<input type="checkbox"/>	<input type="checkbox"/>	<input type="checkbox"/>	<input type="checkbox"/>
LFE Channel	LFE Channel Off	LFE Channel Off	<input type="checkbox"/>	<input type="checkbox"/>	<input type="checkbox"/>	<input type="checkbox"/>	<input type="checkbox"/>	<input type="checkbox"/>	<input type="checkbox"/>
Dialogue Normalization	-23dB	-27dB	<input type="checkbox"/>	<input type="checkbox"/>	<input type="checkbox"/>	<input type="checkbox"/>	<input type="checkbox"/>	<input type="checkbox"/>	<input type="checkbox"/>
Audio Production Information	Present	Not Present	<input type="checkbox"/>	<input type="checkbox"/>	<input type="checkbox"/>	<input type="checkbox"/>	<input type="checkbox"/>	<input type="checkbox"/>	<input type="checkbox"/>
Mix Level	111dB SPL	80dB SPL	<input type="checkbox"/>	<input type="checkbox"/>	<input type="checkbox"/>	<input type="checkbox"/>	<input type="checkbox"/>	<input type="checkbox"/>	<input type="checkbox"/>
• • •									
DC Highpass Filter	Bypassed	Enabled	<input type="checkbox"/>	<input type="checkbox"/>	<input type="checkbox"/>	<input type="checkbox"/>	<input type="checkbox"/>	<input type="checkbox"/>	<input type="checkbox"/>
Bandwidth Lowpass Filter	Bypassed	Enabled	<input type="checkbox"/>	<input type="checkbox"/>	<input type="checkbox"/>	<input type="checkbox"/>	<input type="checkbox"/>	<input type="checkbox"/>	<input type="checkbox"/>
LFE Channel Lowpass Filter	Bypassed	Enabled	<input type="checkbox"/>	<input type="checkbox"/>	<input type="checkbox"/>	<input type="checkbox"/>	<input type="checkbox"/>	<input type="checkbox"/>	<input type="checkbox"/>
Surround Channel 90 Degree PSF	Bypassed	Enabled	<input type="checkbox"/>	<input type="checkbox"/>	<input type="checkbox"/>	<input type="checkbox"/>	<input type="checkbox"/>	<input type="checkbox"/>	<input type="checkbox"/>
Surround Channel Attenuator	Bypassed	Bypassed	<input type="checkbox"/>	<input type="checkbox"/>	<input type="checkbox"/>	<input type="checkbox"/>	<input type="checkbox"/>	<input type="checkbox"/>	<input type="checkbox"/>
RF Compression Exists	Not Present	Not Present	<input type="checkbox"/>	<input type="checkbox"/>	<input type="checkbox"/>	<input type="checkbox"/>	<input type="checkbox"/>	<input type="checkbox"/>	<input type="checkbox"/>
RF Compression Profile 1	Film: Standard	Film: Standard	<input type="checkbox"/>	<input type="checkbox"/>	<input type="checkbox"/>	<input type="checkbox"/>	<input type="checkbox"/>	<input type="checkbox"/>	<input type="checkbox"/>
DRC Exists	Not Present	Not Present	<input type="checkbox"/>	<input type="checkbox"/>	<input type="checkbox"/>	<input type="checkbox"/>	<input type="checkbox"/>	<input type="checkbox"/>	<input type="checkbox"/>
DRC Profile 1	Music: Light	Film: Standard	<input type="checkbox"/>	<input type="checkbox"/>	<input type="checkbox"/>	<input type="checkbox"/>	<input type="checkbox"/>	<input type="checkbox"/>	<input type="checkbox"/>

Table 1 +DEC Option Control List and Descriptions — continued

<p><b>Metadata Routing and Embedding</b></p>	<p>Provides input and output support of Dolby metadata routing between the Dolby decoder and serial/video interfaces.</p>
<p><b>Note:</b></p> <ul style="list-style-type: none"> <li>• “Dolby Decoder” drop-down choices and “Dolby Encoder” selector for this function appear only on cards equipped with a Dolby decoder and/or Dolby encoder.</li> <li>• After familiarizing yourself with the controls described here, see the following page for an example showing interrelated use of these controls.</li> </ul>	
<p><b>• Serial Port Output Source Selectors</b></p> <p>Serial Port A Metadata Source <input type="text" value="Dolby decoder"/></p> <p>Serial Port B Metadata Source <input type="text" value="None"/></p>	<p>For serial ports A and B, selects the source for metadata to be <b>exported (outputted) from the card</b> over a port as shown from the choices listed to the left and shown below. (<b>None</b> selection frees the port to be used as an input.)</p>  <p><b>Note:</b> If settings here and described below attempt to set a given port as both an output and an input, <b>Serial Ports Conflicts</b> status display indicates conflict (e.g., “Port A configured as both input and output”).</p>
<p><b>• Embedded Output Metadata Source Selector</b></p> <p>Embedded Output Metadata Source <input type="text" value="Serial port A"/></p>	<p>For VBI embedding <b>at the card SDI output</b>, selects the source of metadata to be <b>exported (outputted) from the card</b> from the choices listed to the left and shown below.</p> 
<p><b>• Dolby Encoder Metadata Source Selector</b></p> <p>Dolby Encoder Metadata Source <input type="text" value="Serial port A"/></p>	<p>Selects the metadata source to be <b>imported (inputted) to an on-card Dolby encoder</b> from the choices listed to the left and shown below.</p>  <p><b>Note:</b> Dolby Decoder described here is Dolby decoder function co-located on card.</p>
<p><b>• SDI Input VBI Metadata Status Display</b></p> <p>Input Status <input type="text" value="Receiving embedded metadata on line 13"/></p>	<p>Indicates if Dolby metadata is present on input SDI VBI, as well as VBI line number. (If no metadata present, displays “Not Present”).</p>

Table 1 +DEC Option Control List and Descriptions — continued

Metadata Routing and Embedding	(continued)
<p>• <b>Metadata Embedding</b></p> <div style="border: 1px solid #ccc; padding: 5px; margin-bottom: 10px;"> <p>Embedded Metadata Output <span style="float: right;">On</span></p> <p>Embedded Output Line <span style="float: right;">13</span></p> </div>	<p><b>Embedded Metadata Output</b> enables SMPTE 2020-1 metadata embedding in the SDI video output, as selected using controls described above.</p> <p>Embedded Output Line allows selection of SMPTE 2020-1 metadata line location within the VANC space for re-inserted Dolby® metadata.</p> <p>(Range is 9 thru 41)</p> <p><b>Note:</b></p> <ul style="list-style-type: none"> <li>• Although the output line drop-down will allow any choice within the 9 thru 41 range, the actual range is automatically clamped (limited to) certain ranges to prevent inadvertent conflict with active picture area depending on video format.</li> <li>• The card does not check for conflicts on a given line number. Make certain the selected line is available and carrying no other data unless existing metadata is to be intentionally overwritten.</li> </ul> <p>Typically, when encoding is active it is recommended that whatever metadata source the encoder is using (e.g., input video SMPTE 2020, decoder, or serial) be also applied to metadata output embedding, and also that the line number be set to overwrite obsolete input VBI metadata. This avoids any ambiguity of having different metadata packets on multiple lines.</p>

### Metadata Routing Examples

In this example, the on-card Dolby encoder is to receive external metadata over serial port B. Also, the new metadata from the on-card decoder is to be inserted into the SDI output SMPTE 2020 VBI and exported from the card over serial port A.

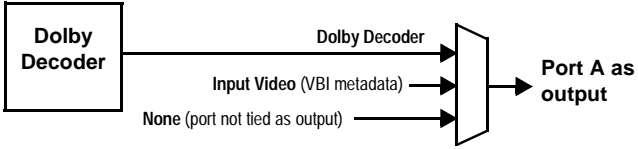
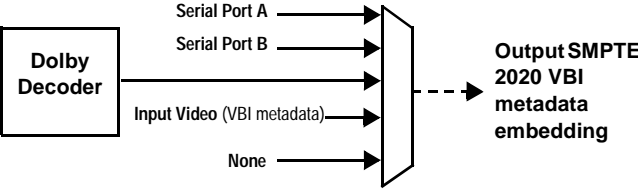
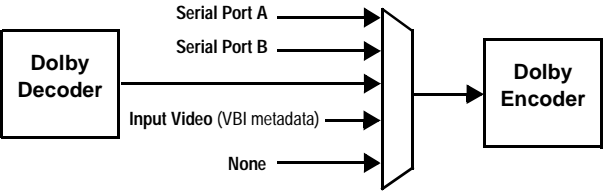
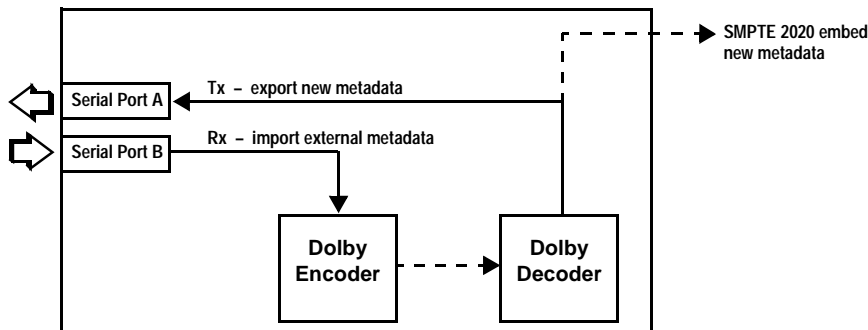
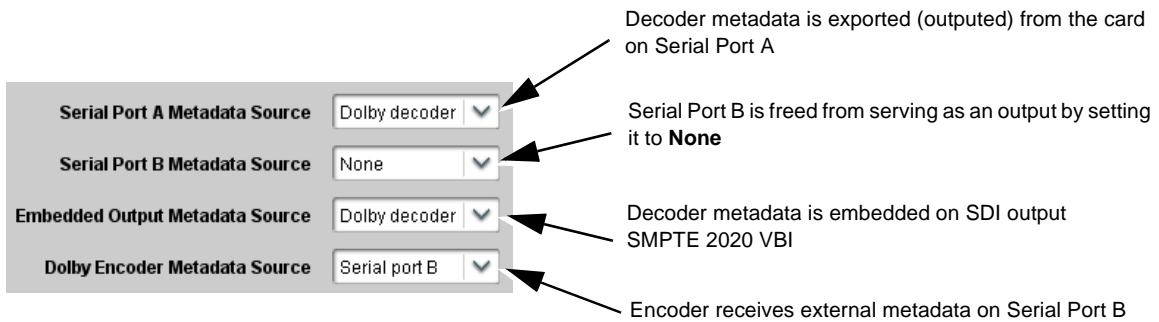
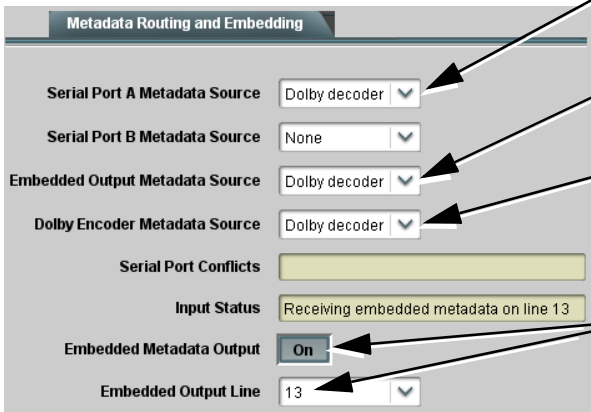
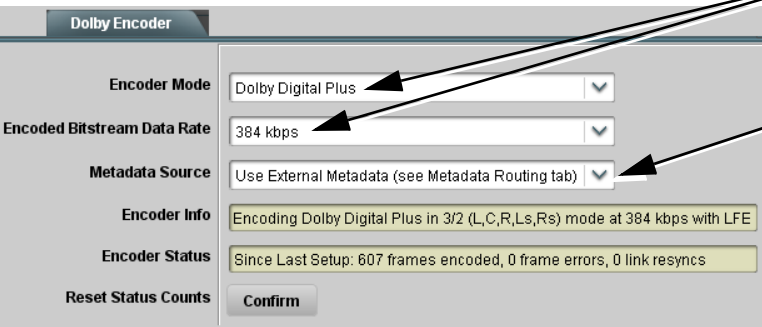
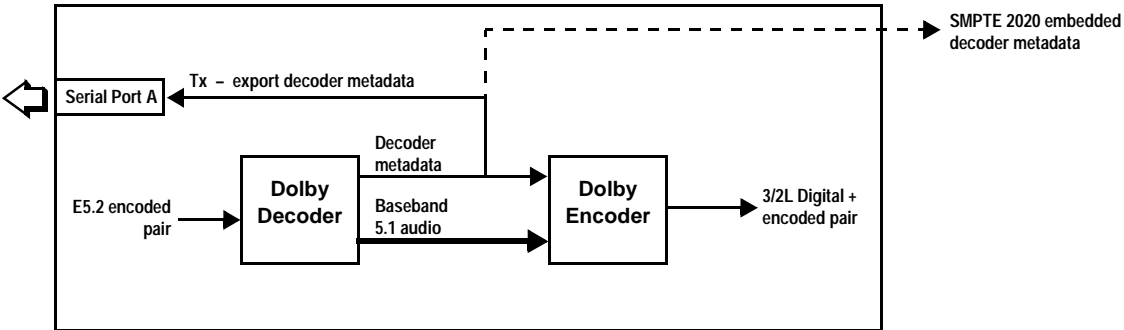

Table 1 +DEC Option Control List and Descriptions — continued

<b>Metadata Routing and Embedding</b>	<b>(continued)</b>
<p><b>Metadata Routing Examples (cont.)</b></p> <p>In this example, the on-card Dolby decoder is to receive and decode Dolby E5.1. The baseband outputs are then to be fed to the on-card Dolby Digital encoder, which in turn is set to encode the six audio channels as Dolby Digital Plus 3/2L using metadata from the decoder. Additionally, the decoder metadata is to be outputted from the card over Serial Port A as well as on the SDI output (SMPTE 2020 VBI on line 13).</p> <p>Note that this setup uses metadata <b>directly</b> from the decoder. In setups like this where external metadata is to directly control an encoder, intermediate processing elements (such as upmixing or loudness processing) <b>should not</b> be inserted in the baseband audio path between the decoder and encoder (“Baseband 5.1 audio” in the example below); if intermediate processing elements are included, metadata values from the decoder will not be in agreement with the baseband audio fed to the encoder.</p>	
 <p>Annotations for Metadata Routing and Embedding panel:</p> <ul style="list-style-type: none"> <li>Decoder metadata is exported (outputted) from the card on Serial Port A</li> <li>Decoder serves as the metadata source for SMPTE 2020 SDI output embedding</li> <li>Decoder serves as the external metadata source for the on-card Dolby encoder</li> <li>SMPTE 2020 SDI output metadata embedding is enabled and set for VBI line 13</li> </ul>	
 <p>Annotations for Dolby Encoder panel:</p> <ul style="list-style-type: none"> <li>On the on-card Dolby encoder, Mode and Rate are set for Dolby Digital Plus as desired</li> <li>The encoder is set to use external metadata (in this case, on-card decoder metadata as set on the Metadata Routing and Embedding tab shown above)</li> </ul>	
 <p>Block Diagram Description:</p> <ul style="list-style-type: none"> <li><b>Serial Port A</b>: Tx - export decoder metadata</li> <li><b>Dolby Decoder</b>: Receives E5.2 encoded pair, outputs Decoder metadata and Baseband 5.1 audio.</li> <li><b>Dolby Encoder</b>: Receives Baseband 5.1 audio and Decoder metadata, outputs 3/2L Digital + encoded pair.</li> <li><b>SMPTE 2020 embedded decoder metadata</b>: Output from the Dolby Decoder.</li> </ul>	

---

## Routing Loudness Processed Channels to Outputs

Dolby decoder output channels are identified as **Dolby Decoder Out 1** thru **8**, and **Dolby Decoder Downmix L** and **R** on the card **Audio Bus Input Routing/ Controls** tab (for routing to the card audio processing bus; these channels can be routed in the same manner as other sources for card audio inputs).

**Note:** On our website, go to **Support>Documents>Reference Manuals> Fusion3G: E Decode to Digital Plus Decode** link at [www.cobaltdigital.com](http://www.cobaltdigital.com) for an application note with examples using loudness processing and audio routing in general.





**Cobalt Digital Inc.**

2406 E. University Ave.  
Urbana, IL 61802  
Voice 217.344.1243 • Fax 217.344.1245  
[www.cobaltdigital.com](http://www.cobaltdigital.com)

---