

9000-Series

Audio Mixing Bus (AMx) Option

Manual Supplement



Cobalt Digital Inc.

2406 E. University Ave.
Urbana, IL 61802
Voice 217.344.1243 • Fax 217.344.1245
www.cobaltdigital.com

Copyright

©Copyright 2009, Cobalt Digital Inc. All Rights Reserved.

Duplication or distribution of this manual and any information contained within is strictly prohibited without the express written permission of Cobalt Digital Inc. This manual and any information contained within, may not be reproduced, distributed, or transmitted in any form, or by any means, for any purpose, without the express written permission of Cobalt Digital Inc. Reproduction or reverse engineering of software used in this device is prohibited.

Disclaimer

The information in this document has been carefully examined and is believed to be entirely reliable. However, no responsibility is assumed for inaccuracies. Furthermore, Cobalt Digital Inc. reserves the right to make changes to any products herein to improve readability, function, or design. Cobalt Digital Inc. does not assume any liability arising out of the application or use of any product or circuit described herein. **This manual is a supplement and is incomplete unless used with an Owner's or Product Manual. Refer to the applicable Product Manual for complete personnel protection and equipment safety information.**

Trademark Information

Cobalt[®] is a registered trademark of Cobalt Digital Inc.

COMPASS[™] is a trademark of Cobalt Digital Inc.

DashBoard[™] and **openGear**[™] are trademarks of Ross Video Limited. **Dolby**[®] is a registered trademark of Dolby Laboratories, Inc. Other product names or trademarks appearing in this manual are the property of their respective owners.

Manual No.:	OPT-SW-AMX-MS
Document Version:	2.0
Release Date:	December 4, 2009

Overview

This manual supplement provides descriptions and operating instruction for the Audio Mixing Bus Option on Cobalt® COMPASS™ (9000-Series) cards equipped with this option. This option is can be purchased upon initial order, or field-activated using a key string which is sent to you when this option is purchased.

Additional functions, displays, and/or controls for the Audio Mixing Bus Option are described in this supplement. Refer to the card Owner or Product Manual for all other information pertaining to the card.

Note: Generic information provided here in examples may include functionality not present on a particular card (for example, discrete AES input/outputs described here which may not be present on some cards).

Audio Mixing Bus Functional Description

(See Figure 1.) This function provides a 6-to-1 x 6 mixer that allows six groups of any six audio inputs to be mono-mixed into six independent mono buses (**Mix Bus A** thru **Mix Bus F**). As such, each of 36 available input channels can be sourced from any of the audio types handled by a particular card (e.g., AES, embedded, analog, or Dolby® decoded channels where available) and mixed into six groups that in turn can be directed to AES or embedded output channels.

Figure 2 shows the Audio Mixing Bus DashBoard™ controls.

Note:

- This function does not accept undecoded Dolby® encoded channels as input sources.
- Descriptions and examples here show full audio source/destination capabilities. Actual signal input/output capabilities depend on the card model.

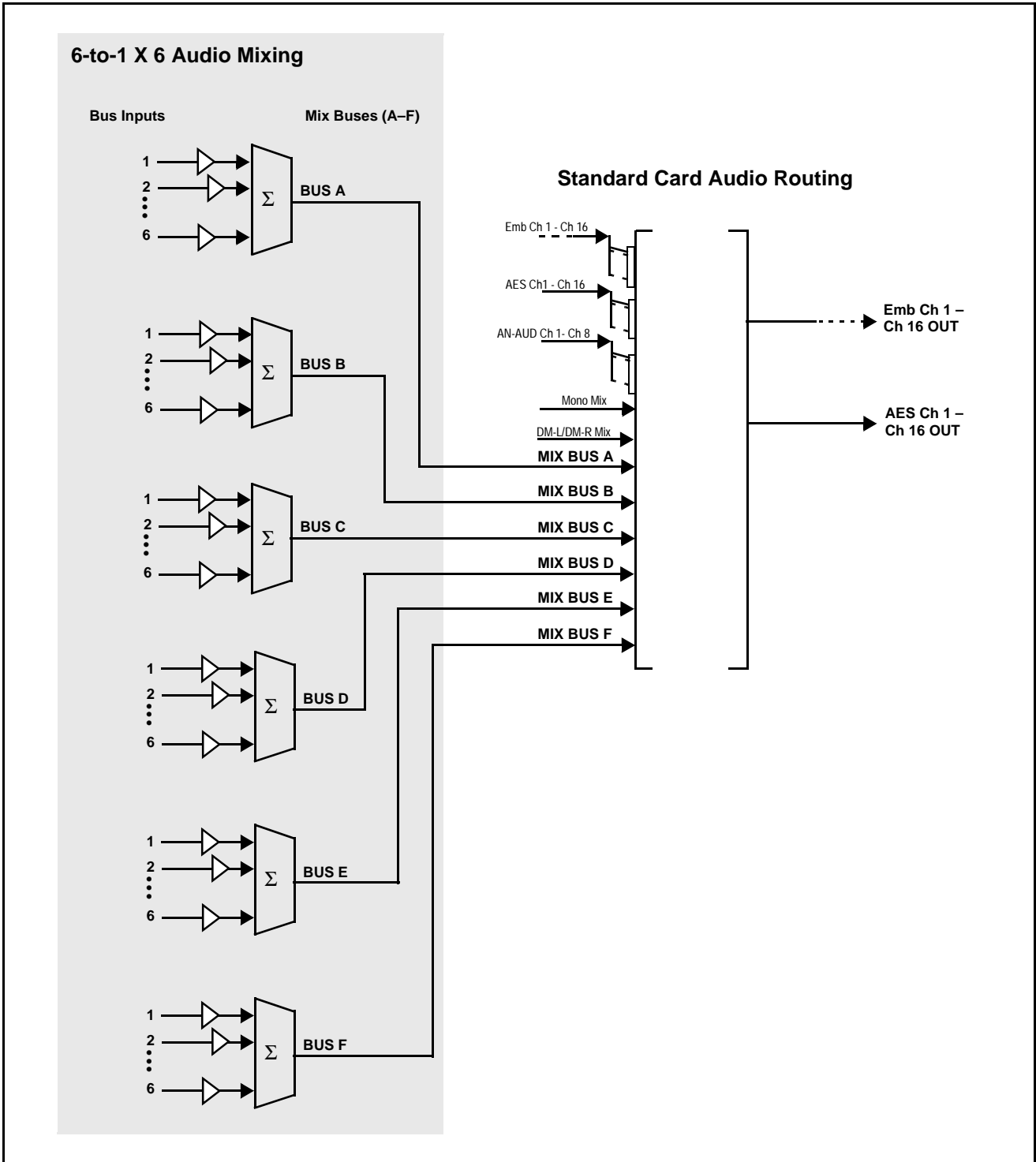

Figure 1 Audio Mixing Bus Block Diagram

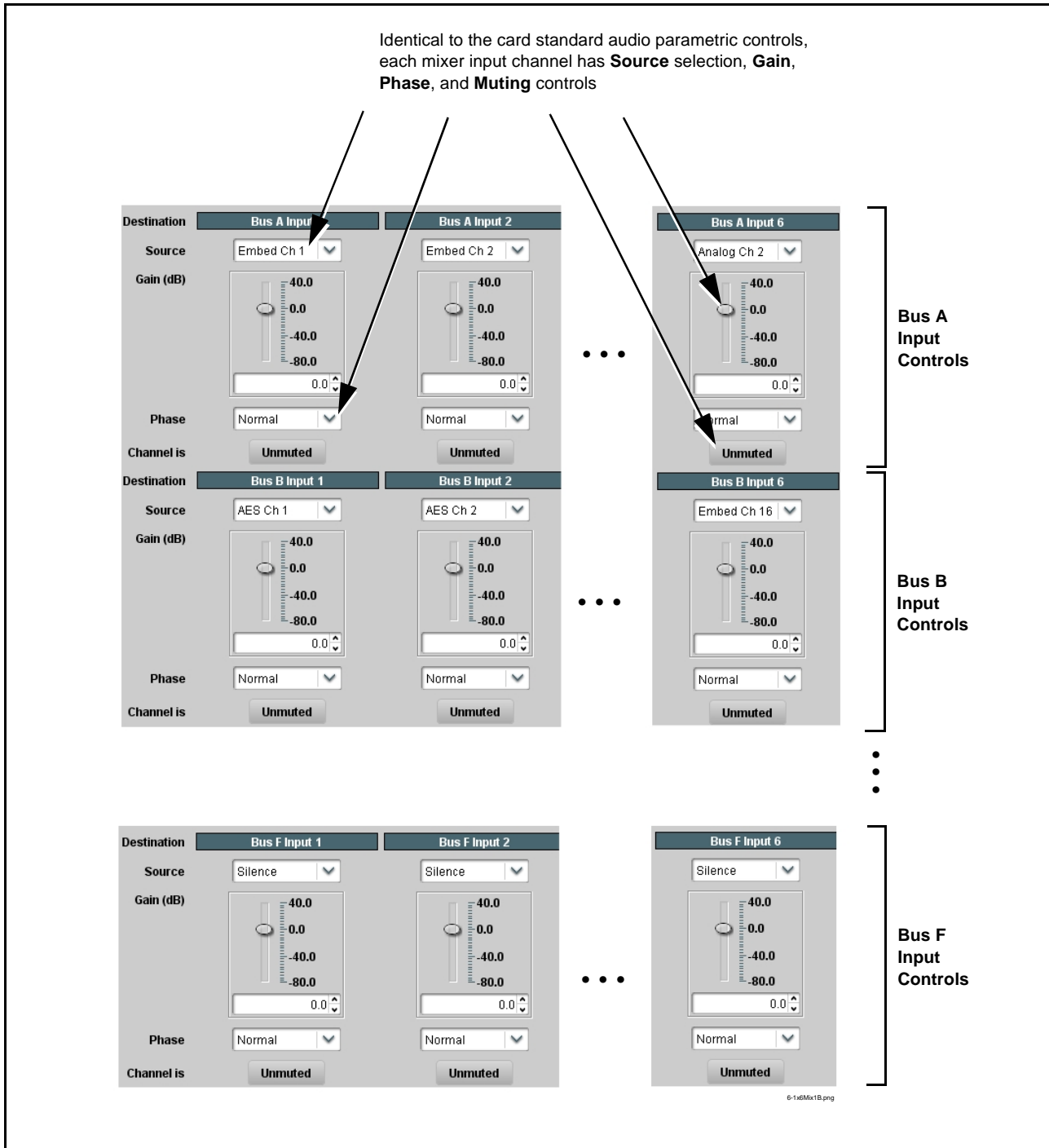



Figure 2 Audio Mixing Bus Dashboard™ Controls

Activating the Audio Mixing Bus Optional Feature

Your card may need activation of this feature by means of a key code which is received from Cobalt® when you purchase this feature.

Presence of this feature of your card is denoted by the **Audio Mixing Bus** tab appearing when the card is opened in DashBoard™.

If this tab does not appear, select the **Licensable Features** tab and activate the feature as described below.

Licensable Features	Allows activation of optional licensed features.
Note: For card pre-ordered with licensed feature(s), the activation steps described below are not required; the feature will already be installed activated. To order features and obtain a license key, contact Cobalt® sales at sales@cobaltdigital.com or at the contact information in your Product Manual. Please provide the "SSN" number of your card (displayed in the Card Info pane) when contacting us for your key.	
• License Feature Key Entry window 	Activate licensable feature as described below. <ol style="list-style-type: none">1. Enter the feature key string in the Feature Key box. Press return or click outside of the box to acknowledge entry. (Entry of a particular key validates activation as well as selects the Audio Mixing Bus feature if multiple optional feature are available for a particular card.) Note: Entry string is case sensitive. Do not enter any spaces.2. In the DashBoard™ Card Info pane, wait for Valid Key Entered to be displayed. This indicates the key was correctly entered and recognized by the card. Note: If DashBoard™ card function submenu/control pane does not re-appear, close the card and re-open it.3. Click and confirm Reboot. When the card function submenu/control pane appears again, the licensable feature will be available. Note: Applying the licensable feature and its reboot has no effect on prior settings. All control settings and drop-down selections are retained.

Audio Mixing Bus Submenu List and Descriptions

Table 1 individually lists and describes the Audio Mixing Bus controls available using DashBoard™ for cards equipped with this feature option. Where helpful, examples showing usage of a control are also provided.

Note: Audio format choices here show full audio source/destination capabilities. Actual format input/output capabilities depend on the card model.

Note: All numeric (scalar) parameters displayed on DashBoard™ can be changed using the slider controls,  arrows, or by numeric keypad entry in the corresponding numeric field. (When using numeric keypad entry, add a return after the entry to commit the entry.)

Table 1 Audio Mixing Bus Control List and Descriptions

	<p>Selects the audio source for each of six inputs for mono mix buses A thru F (36 input channels total). Also provides Gain, Phase Invert, and Muting controls for each mixer input channel.</p>
<p>• Input Channel Source</p> 	<p>Using the Source drop-down list, selects the audio input source to be routed to the corresponding input channel from the choices described below.</p>
<p>• Embedded Ch 1 thru Ch 16 as Source</p> 	<p>Embed Ch 1 thru Embed Ch 16 range in Source drop-down list routes an embedded channel (Ch 1 thru Ch 16) to be the source for the selected mixer input channel.</p> <p>(In this example, Embed Ch 1 (embedded Ch 1) is the source for destination Bus A, Input 1)</p>
<p>• AES Ch 1 thru AES Ch 16 as Source</p> 	<p>AES Ch 1 thru AES Ch 16 range in Source drop-down list routes a discrete AES channel (Ch 1 thru Ch 16) to be the source for the selected mixer input channel.</p> <p>(In this example, AES Ch 1 is the source for destination Bus A, Input 1)</p>
<p>• Analog Ch 1 thru Ch 8 as Source</p> 	<p>Analog Ch 1 thru Analog Ch 8 range in Source drop-down list routes a balanced-input analog channel (Ch 1 thru Ch 8) to be the source for the selected mixer input channel.</p> <p>(In this example, Analog Ch1 is the source for destination Bus A, Input 1)</p>

Table 1 Audio Mixing Bus Control List and Descriptions — continued



	(continued)
<p>• Dolby® Decoded Channel as Source</p> 	<p>(-DEC models only) Dolby Ch 1 thru Dolby Ch 8 range in Source drop-down list enables a Dolby® decoded channel to be the source for the selected mixer input channel.</p> <p>(In this example, Dolby® decoded Ch 1 is the source for destination Bus A, Input 1)</p> <p>Note: Drop-down choices of Ch 1 thru Ch 8 and Mix 1/Mix 2 represent maximum channels available. Actual active channel complement is per received Dolby® format and upstream encoding. Inactive channels should not be used.</p>
<p>• Tone Generator 1 thru 4 as Source</p> 	<p>Tone Generator 1 thru Tone Generator 4 range in Source drop-down list enables one of four tone generators (Tone 1 thru Tone 4) to be the source for the selected mixer input channel.</p> <p>(In this example, Tone 1 (tone generator 1) is the source for destination Bus A, Input 1)</p>
<p>• Silence (Mute) as Source</p> 	<p>Silence selection in Source drop-down list mutes the selected mixer input channel. Use this setting for unused input channels.</p> <p>(In this example, silence (muting) is applied to Bus A, Input 1)</p> <p>Note: Factory card preset sets all input channels to Silence setting.</p>
<p>• Gain (dB) Control</p> 	<p>Adjusts and displays relative gain (in dB) applied to the corresponding mixer input channel.</p> <p>(-80 to +40 dB range in 0.1 dB steps; unity = 0.0 dB)</p>

Table 1 Audio Mixing Bus Control List and Descriptions — continued

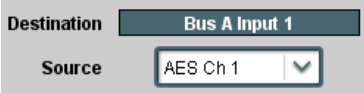
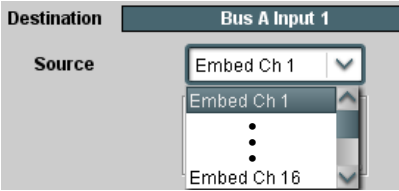
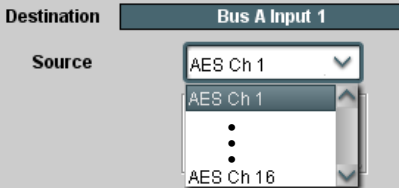
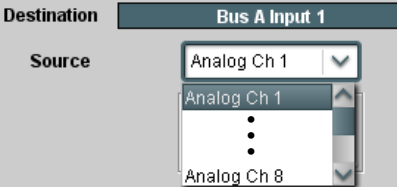
<div style="background-color: #333; color: white; padding: 5px; text-align: center; font-weight: bold;">Audio Mixing Bus</div>	<p>(continued)</p>
<p>• Mute Control</p> 	<p>Allows pushbutton On/Off input channel muting while saving all other settings.</p>
<p>• Phase Control</p> 	<p>Selects between Normal and Invert phase (relative to source original phase) for the mixer input channel.</p>
<div style="border: 1px solid black; padding: 5px; text-align: center; font-weight: bold;">Bus Output Routing</div>	<p>Routing of the six mono-mixed bus outputs (Mix Bus A thru Mix Bus F) is performed the same as routing any other source to a destination embedded or AES output channel as described below.</p>
<p>• Bus Output Routed To Embedded Channel</p> 	<p>Using the Source drop-down list in the Embedded Audio Group 1/2 or Embedded Audio Group 3/4 tab, any of the six mono-mix buses (Mix Bus A thru Mix Bus F) can be routed to selected destination output embedded channel.</p> <p>The parametric controls for the destination embedded output channel serve as the post-mix master controls for the mono-mix bus.</p>
<p>• Bus Output Routed To AES Channel</p> 	<p>Using the Source drop-down list in the AES Audio Out Pairs 1-4 or AES Audio Out Pairs 5-8 tab, any of the six mono-mix buses (Mix Bus A thru Mix Bus F) can be routed to selected destination output AES channel.</p> <p>The parametric controls for the destination embedded output channel serve as the post-mix master controls for the mono-mix bus.</p>

Audio Mixing Routing Example

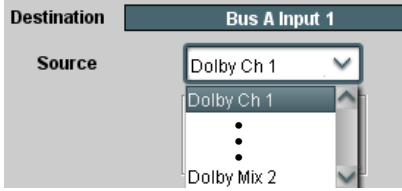
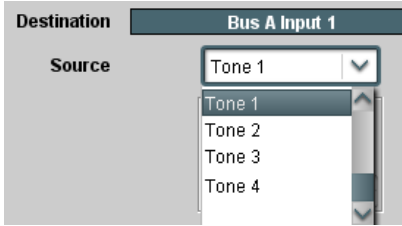
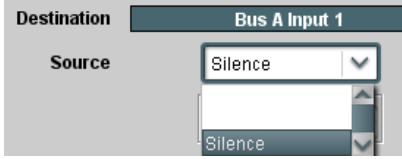
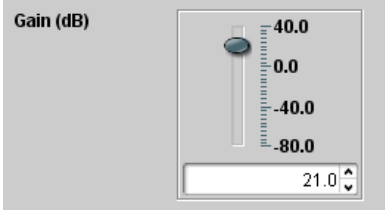
Figure 3 shows an example of using the Audio Mixing **Audio Mixing Bus** tab in conjunction with the standard card audio routing controls to provide a mono-mixed channel from a 5.1 stream received from a Dolby® decoder 5.1 feed, as well as a separate mono mix from an embedded channel pair, resulting in two embedded output channels correspondingly carrying these two individual mono mixes. Note that the source and destination correlations shown here are only examples; **any** source handled by the card can similarly route to **any** destination.

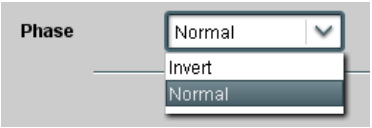
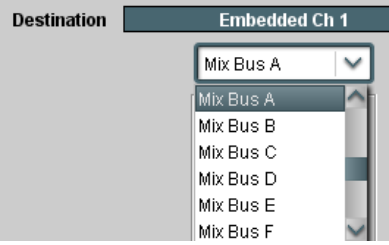
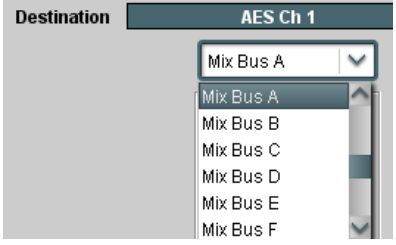
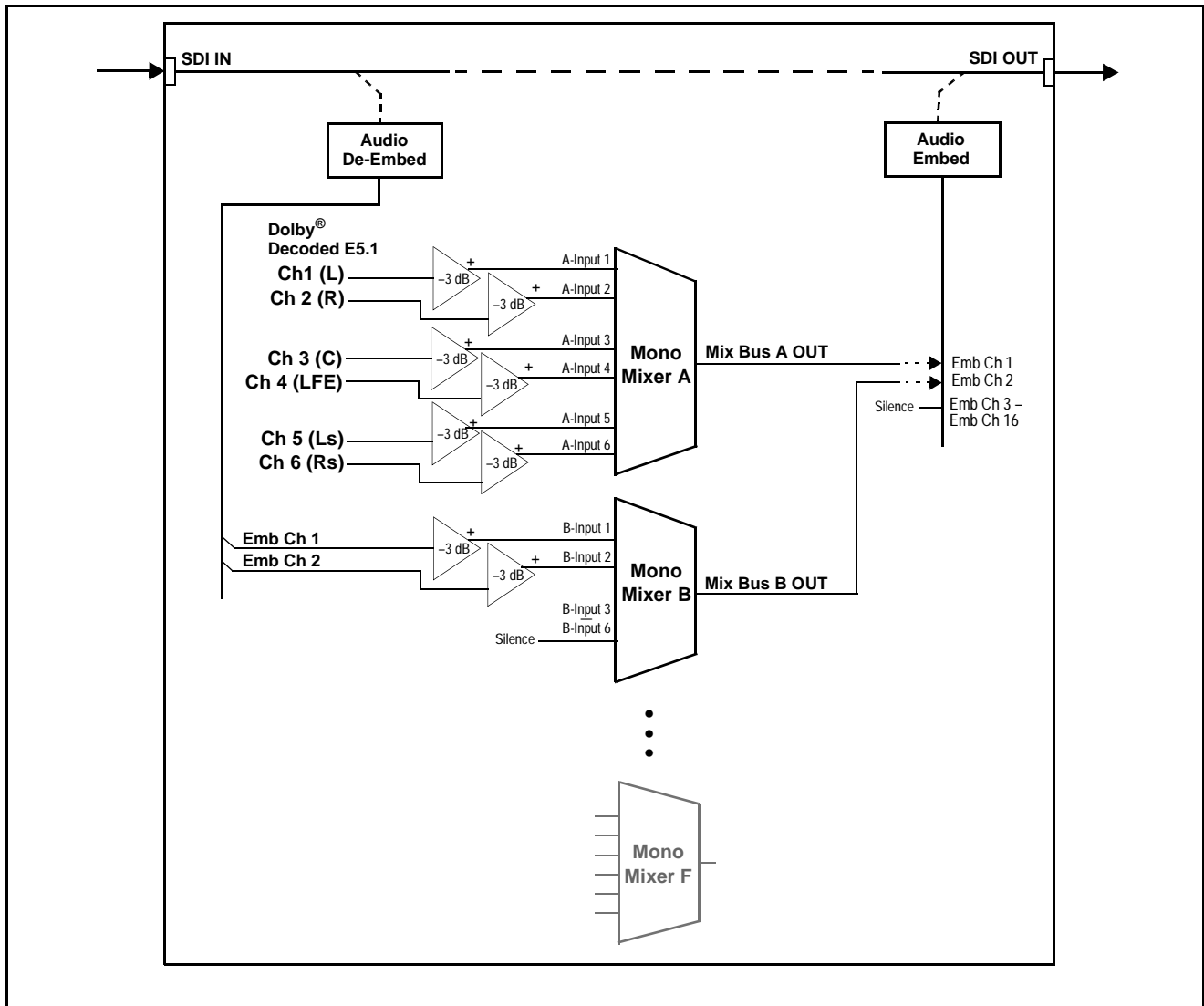
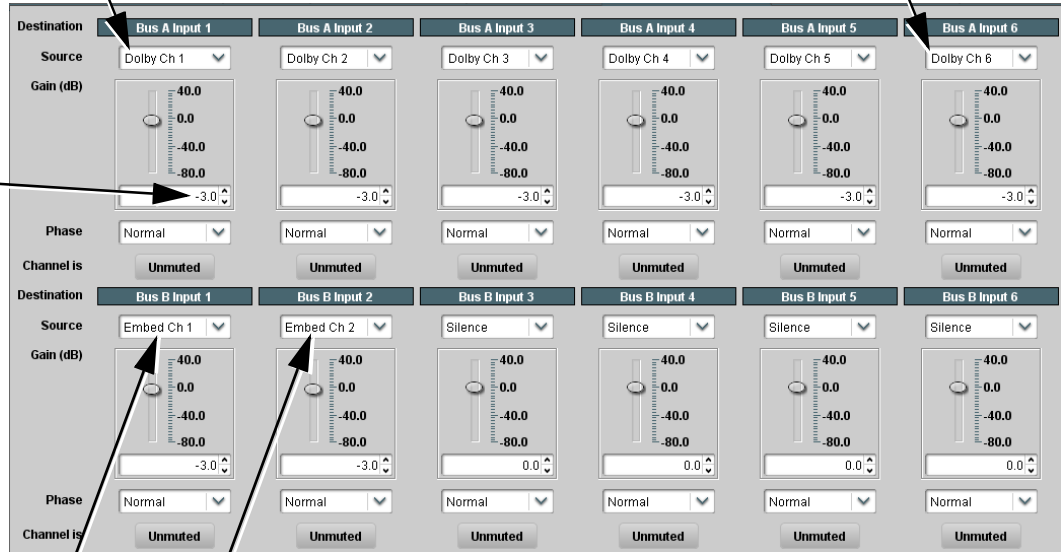

Figure 3 Audio Mixing Bus Example (Sheet 1 of 2)

Figure 3, sheet 2 shows the card control settings (using Dashboard™) that result in this routing.

Using the **Audio Mixing Bus** tab, the six Dolby® decoded channels to be mono-mixed are routed to respective source inputs **Bus A Input 1** thru **Bus A Input 6**. This results in these six inputs being mono-mixed on **Bus A**.

In this example, the required -3 dB gain of each input is set using the individual input channel **Gain (dB)** controls. (Gain can be set using the slider controls or numerically entered.)



In this example, Emb Ch 1 and Emb 2 are mono-mixed into a separate bus by routing these sources to the **Bus B Input 1** and **Bus B Input 2** inputs. This results in these two inputs being mono-mixed on **Bus B**.

The unused inputs for this and other buses can be set to **Silence** as shown.

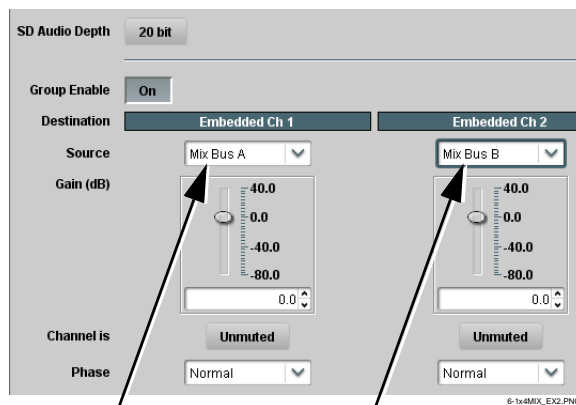

Using the **Embedded Audio Group 1/2** tab, the mixer bus channel outputs (**Mix Bus A** and **Mix Bus B**) can be routed to Emb Ch 1 and Emb Ch 2 as shown in this example.

Note that the parametric controls in this tab can be used as post-mix master controls for the mixed outputs.

Figure 3 Audio Mixing Bus Example (Sheet 2 of 2)



Cobalt Digital Inc.

2406 E. University Ave.
Urbana, IL 61802
Voice 217.344.1243 • Fax 217.344.1245
www.cobaltdigital.com