

---

**F3G  
Fusion**

**Option** 



**Keying Option (+KEYER)**

***Manual Supplement***

---



**Cobalt Digital Inc.**

2406 E. University Ave.  
Urbana, IL 61802  
Voice 217.344.1243 • Fax 217.344.1245  
[www.cobaltdigital.com](http://www.cobaltdigital.com)

---

## Copyright

©Copyright 2011, Cobalt Digital Inc. All Rights Reserved.

Duplication or distribution of this manual and any information contained within is strictly prohibited without the express written permission of Cobalt Digital Inc. This manual and any information contained within, may not be reproduced, distributed, or transmitted in any form, or by any means, for any purpose, without the express written permission of Cobalt Digital Inc. Reproduction or reverse engineering of software used in this device is prohibited.

## Disclaimer

The information in this document has been carefully examined and is believed to be entirely reliable. However, no responsibility is assumed for inaccuracies. Furthermore, Cobalt Digital Inc. reserves the right to make changes to any products herein to improve readability, function, or design. Cobalt Digital Inc. does not assume any liability arising out of the application or use of any product or circuit described herein. **This manual is a supplement and is incomplete unless used with an Owner's or Product Manual. Refer to the applicable Product Manual for complete personnel protection and equipment safety information.**

## Trademark Information

**Cobalt**<sup>®</sup> is a registered trademark of Cobalt Digital Inc.

**FUSION3G**<sup>®</sup> is a registered trademark of Cobalt Digital Inc. **COMPASS**<sup>™</sup> is a trademark of Cobalt Digital Inc.

**openGear**<sup>®</sup> is a registered trademark of Ross Video Limited. **DashBoard**<sup>™</sup> is a trademark of Ross Video Limited.

<b>Manual No.:</b>	OPT-SW-F3GKEYER-MS
<b>Document</b>	
<b>Version:</b>	1.1
<b>Release Date:</b>	September 23, 2011

## Overview

This manual supplement provides descriptions and operating instruction for the +KEYER Option available as an option on new Cobalt® FUSION3G® (9900-Series) cards, and as a purchased field-installed licensable feature upload.

**Note:** If this option is to be field installed, your card must be compatible with supporting the +KEYER option. See below to make sure your card is equipped to support +KEYER option.

If your card displays **Processor Type B** or FPGA Version **.129**, it supports +KEYER.

If your card displays Processor Type A or FPGA Version **.128**, it **does not** support +KEYER. **This option cannot be used with this card type.**

Status	Product
	9901-UDX
⋮	
Software Version	1.0.4662
Processor Type	B
FPGA Version	1.0.4600.129

Processor Type B or FPGA Version **.129** displayed.

## +KEYER Option Functional Description

(See Figure 1.) Option +KEYER provides for three of the card SDI video inputs to be used as respective program video, key, and fill inputs. Providing back-end (post scaler) keying, this function provides chroma keying using the **KEY VID IN** signal. The **FILL VID IN** signal provides the fill video that is inserted in the area “cleared out” by the key. The keying user interface displays key and fill timing relative to the card output video, allowing timing offset to be adjusted such that key and fill can be properly framed. (The option and its host card does not provide timing offset control of the key/fill video; offset must be provided by external frame sync cards or devices controlling the key and fill video feed.) The program video input when using keying accommodates either an SDI or an analog video input (when equipped with analog video in option); key and fill inputs are SDI only.

Alpha threshold keyer modes allow full-color key/fill from cost-effective generic sources such as a standard PC (with appropriate HDMI-to-SDI output conversion) hosting simple .bmp, .jpeg, or .png graphic files. In these modes, a common key/fill SDI input provides both the key and fill input.

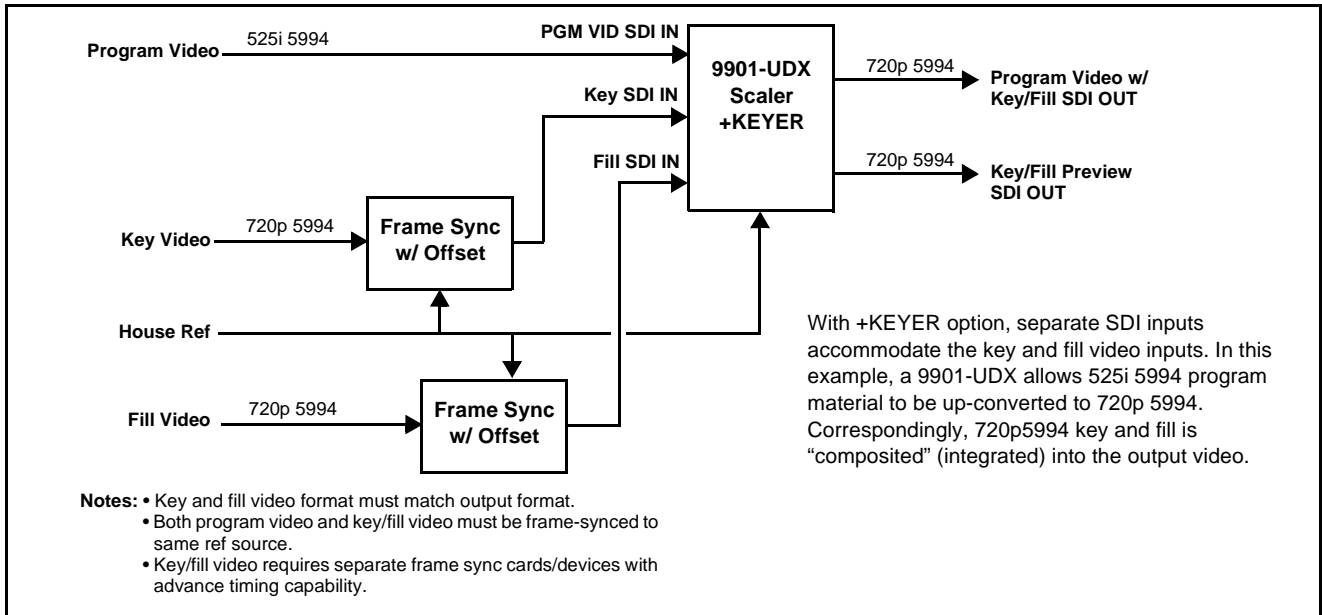


Figure 1 Key/Fill Insertion on Up-converted SD-SDI

## +KEYER Input Routing and Rear I/O Module Selection

(See Figure 2.) Because the +KEYER option requires two additional separate key and fill SDI inputs on the host card, a Rear Module having spare SDI inputs (which serve as the key and fill inputs for cards licensed for +KEYER) is required. Consult “Rear Modules” in card Product Manual for rear module assortment and descriptions.

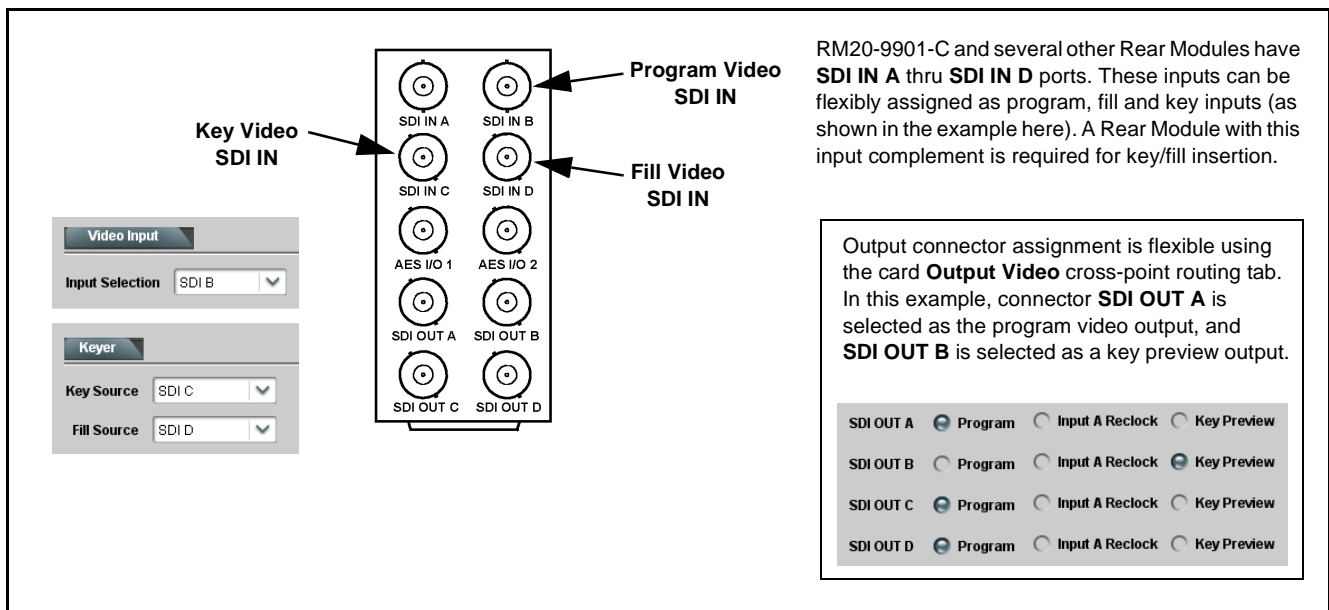


Figure 2 Typical Rear Module and Connections For Key/Fill Insertion

## Uploading Option Feature (Field Upgrade Only)

**Note:** • See important Note on page 1 regarding card compatibility before proceeding.

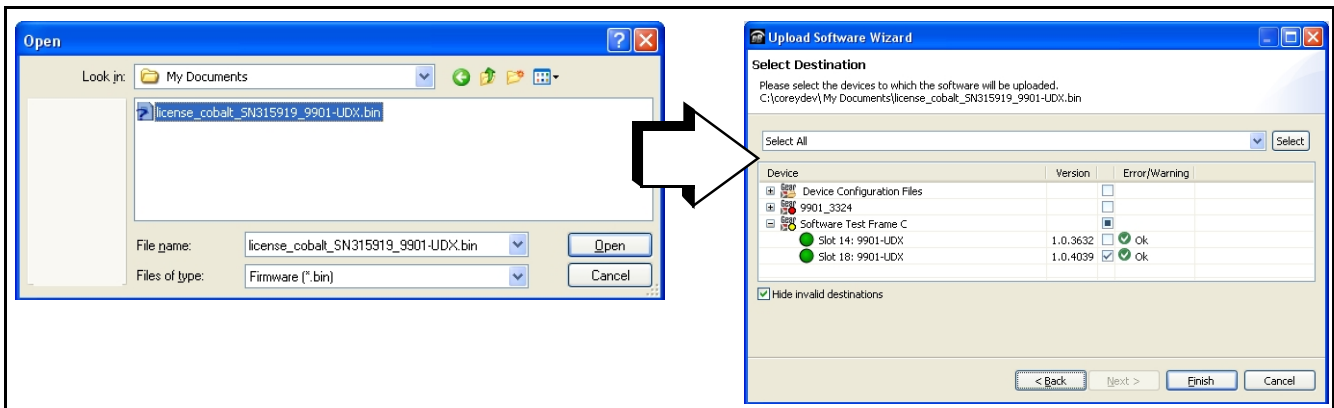
- If your FUSION3G® card was purchased with the option(s) covered here, this procedure is not required for your card. If you have purchased this feature to be field-installed on an existing card, perform the upload procedure here to upload the feature key file sent by Cobalt, and to activate the feature on your card.
- To order features and obtain a license key, contact Cobalt® sales at sales@cobaltdigital.com or at the contact information on the cover of this supplement. Please provide the Serial Number of your card (displayed in the Card Info pane) when contacting us for your feature key. Typically, a feature is tied to the card's serial number and will only work with that card. Please indicate if upgrades are needed for more than one card.

Activate licensable feature as described below.

1. Cobalt typically supplies a .bin file (by e-mail; file size < 10kB) that activates the licensable feature. Download this file to a convenient location on the PC connected to the card's frame.

**Note:** During this procedure, the card will go offline while the feature is installed. Make certain card is not carrying OTA signal.

2. In DashBoard for the card being upgraded click the **Upload** button and browse to the feature license file (in the example below, license\_cobalt\_SN315909\_9901-UDX.bin).



3. Select the file, click **Open** and then follow the prompts. With intended card selected (“Slot 18 UDX-9901” in example above), click **Finish**. When the card comes back online, the feature appears in the DashBoard controls and is ready for use.

**Note:** Applying the licensable feature has no effect on prior settings. All control settings and drop-down selections are retained.


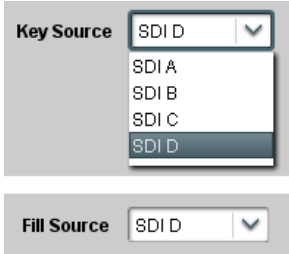
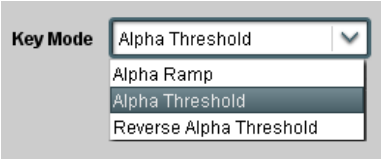
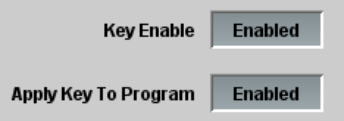
**Note:** Added features, when first appearing after installation, are set to their factory default states. For features having a direct impact on the output signal, all controls are initially set to disabled or null.

# Keyer Controls and Examples


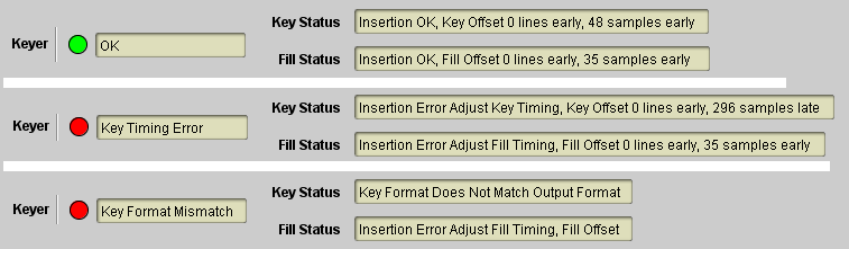

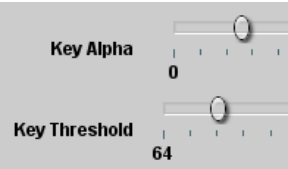
Table 1 individually lists and describes typical Key and Fill controls available using DashBoard™ for FUSION3G® cards equipped with the +KEYER option.

- See Key/Fill Setup Example (Alpha Ramp with Separate Key/Fill Inputs), p. 6 for an example showing how to set discrete key and fill insertion timing and insertion width using DashBoard controls.
- See Key/Fill Setup Example (Alpha Threshold Using Combined Key/Fill Input), p. 7 for an example showing how to set combined key/fill insertion timing and properties using DashBoard controls.

**Table 1 +KEYER Option Control List and Descriptions**

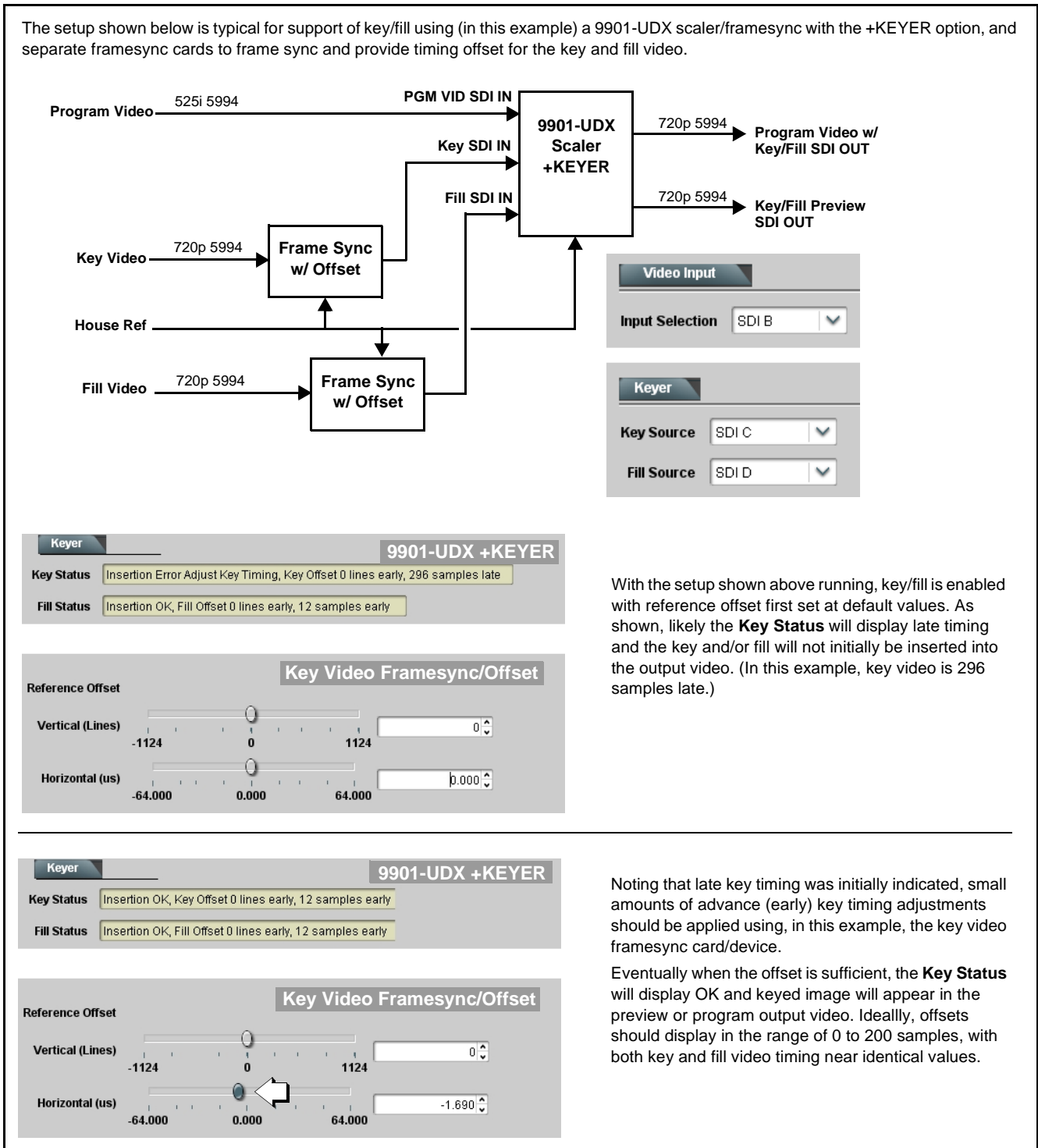
	<p>Provides key/fill insertion controls and displays insertion status.</p>
<p><b>Option</b> ➔ Key/fill controls described below only appear on cards with + KEYER licensed optional feature. This feature requires a Rear Module that accommodates separate key/fill video inputs. Note that on cards also licensed with +WINGS, Wings and Keyer controls appear on the same tab.</p>	
<p>• <b>Key/Fill Source Controls</b></p> 	<p>Selects the card SDI input video ports to serve as the card's key and fill sources.</p> <p><b>Note:</b></p> <ul style="list-style-type: none"> <li>• Choices shown here are examples only. Card may not have full complement shown.</li> <li>• SDI inputs selected must be used on Rear I/O Module correspondingly equipped with intended input ports.</li> </ul>
<p>• <b>Key Mode Control</b></p> 	<p>Selects key mode as follows:</p> <ul style="list-style-type: none"> <li>• <b>Alpha Ramp</b> setting is used when typical key/fill is provided by key/fill generator with separate key and fill outputs. See Key/Fill Setup Example (Alpha Ramp with Separate Key/Fill Inputs), p. 6 for more information.</li> <li>• <b>Alpha Threshold</b> or <b>Reverse Alpha Threshold</b> setting is used to provide keying using a combined key/fill signal derived from a simple graphic source. See Key/Fill Setup Example (Alpha Threshold Using Combined Key/Fill Input), p. 7 for more information.</li> </ul>
<p>• <b>Key/Fill Insertion Enable Control</b></p> 	<p><b>Key Enable</b> control sets up key/fill for insertion. When enabled, key preview is available on Key Preview output.</p> <hr/> <p>When key preview shows desired results, <b>Apply Key To Program</b> can be enabled to apply the key/fill to the program video output.</p>

**Table 1 +KEYER Option Control List and Descriptions — continued**

	(continued)
<p>• <b>Key/Fill Status Displays</b></p> 	<p>Displays keyer timing status (on both Keyer tab and Card Status displays) as described below.</p> <p><b>Note:</b></p> <ul style="list-style-type: none"> <li>• Key/fill timing is a function of the respective key and fill signal frame sync card/device(s). Ideal timing is <b>within 0 to 200 samples early</b> of output video timing. Key/fill timing cannot be controlled on +KEYER host card.</li> <li>• Error in key/fill timing will result in loss of keying (however, program video image will not be corrupted).</li> </ul> <p>Key/fill insertion OK, within target 0-200 samples early</p> <hr/> <p>Key or fill insertion late error</p> <hr/> <p>Key or fill video wrong/mismatched format</p>
<p>• <b>Suppress Registration Warning Control</b></p> 	<p>Enables or disables keying vertical alignment error message/status display, allowing nuisance error messages to be suppressed while performing setup.</p>
<p>• <b>Key Alpha/Threshold Controls</b></p> 	<p>When keying is set to Alpha Threshold or Reverse Alpha Threshold mode sets luma thresholds, when crossed, allow key/fill onto program video image.</p> <p><b>Key Alpha</b> setting, when increased, increases the opacity of the key/fill.</p> <hr/> <p><b>Key Threshold</b> setting, when reduced, more readily allows the key/fill input to assert itself over more variations of program video luma levels.</p> <p>See Key/Fill Setup Example (Alpha Threshold Using Combined Key/Fill Input), p. 7 for examples using these controls.</p>

## Key/Fill Setup Example (Alpha Ramp with Separate Key/Fill Inputs)

Figure 3 shows an example of alpha ramp keying using separate 720p 5994 key and fill sources for program material set for a 720p 5994 format output. Note that the key and fill insertion timing is controlled by separate key and fill video framesync cards/devices.



With the setup shown above running, key/fill is enabled with reference offset first set at default values. As shown, likely the **Key Status** will display late timing and the key and/or fill will not initially be inserted into the output video. (In this example, key video is 296 samples late.)

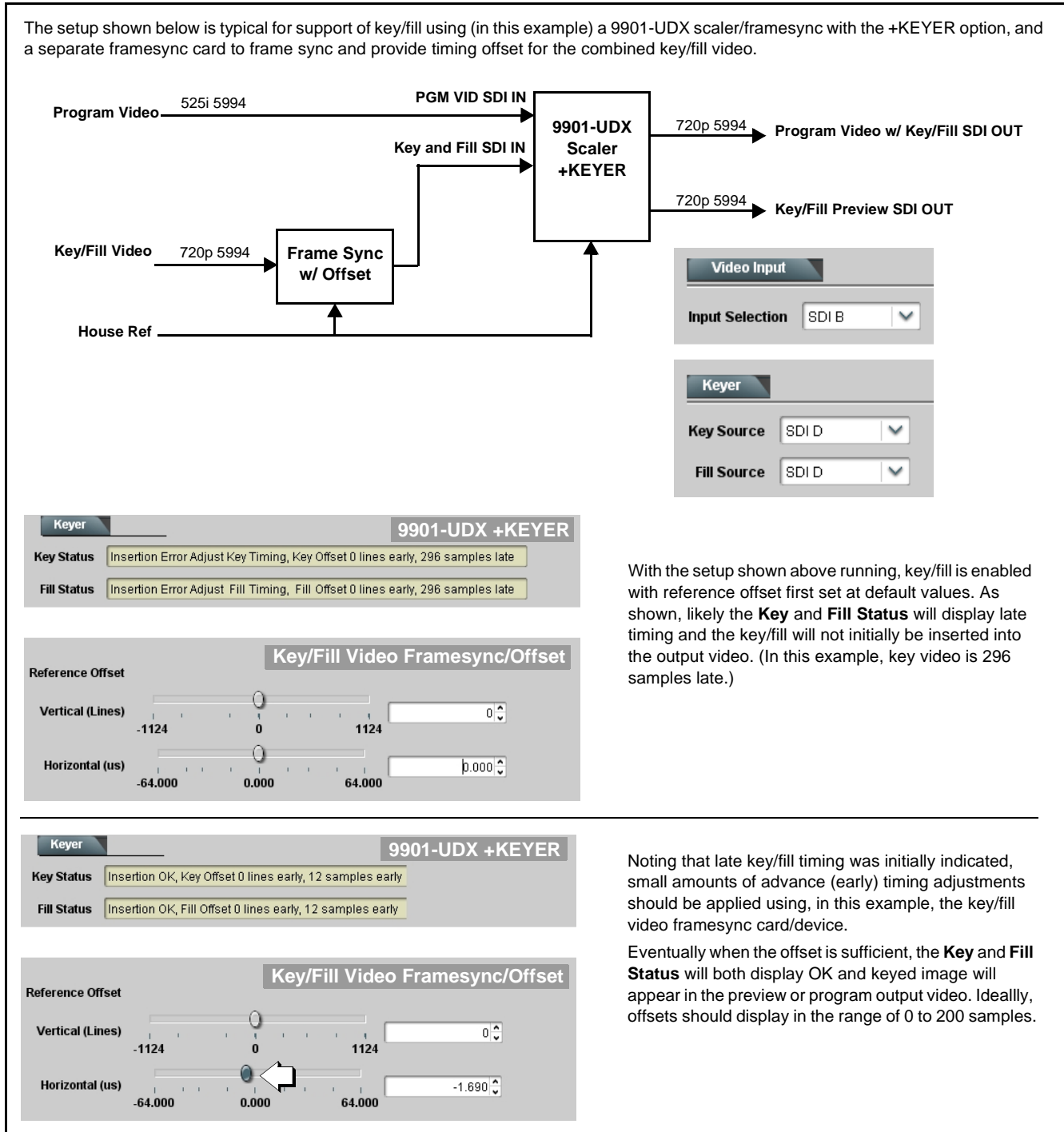
Noting that late key timing was initially indicated, small amounts of advance (early) key timing adjustments should be applied using, in this example, the key video framesync card/device.

Eventually when the offset is sufficient, the **Key Status** will display OK and keyed image will appear in the preview or program output video. Ideally, offsets should display in the range of 0 to 200 samples, with both key and fill video timing near identical values.

**Figure 3 Key/Fill Timing Setup Using Discrete Key and Fill Video (Alpha Ramp Mode)**

## Key/Fill Setup Example (Alpha Threshold Using Combined Key/Fill Input)

Figures 4 and 5 show an example of alpha threshold keying using a combined 720p 5994 key/fill source for program material set for a 720p 5994 format output. In this mode, both the **Key Source** and **Fill Source** are set to use the same SDI input. Note that the key/fill insertion timing is controlled by a separate key/fill video framesync card/device.



With the setup shown above running, key/fill is enabled with reference offset first set at default values. As shown, likely the **Key** and **Fill Status** will display late timing and the key/fill will not initially be inserted into the output video. (In this example, key video is 296 samples late.)

Noting that late key/fill timing was initially indicated, small amounts of advance (early) timing adjustments should be applied using, in this example, the key/fill video framesync card/device.

Eventually when the offset is sufficient, the **Key** and **Fill Status** will both display OK and keyed image will appear in the preview or program output video. Ideally, offsets should display in the range of 0 to 200 samples.

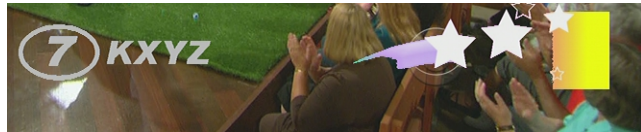
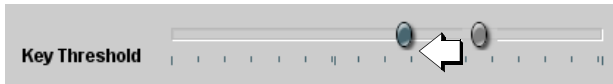
**Figure 4 Key/Fill Timing Setup Using Combined Key/Fill Video (Alpha Ramp Mode)**



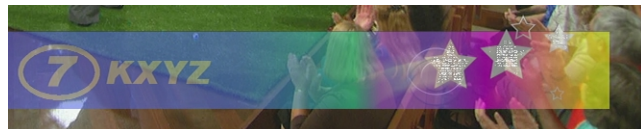
**Alpha Threshold** keying allows cost-effective luminance keying from low-cost generic file-based graphic sources. With the graphic source applied to both the card **Key** and **Fill** inputs, the card **Key Alpha** and **Key Threshold** controls can be set to easily optimize the key/fill as shown below.



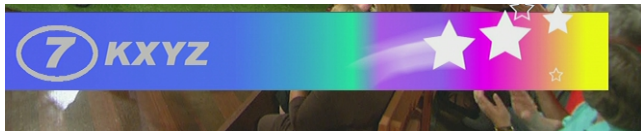
**Key Threshold** setting, when reduced, more readily allows the key/fill input to assert itself over more variations of program video luma levels. In the example to the right, progressively reducing the threshold setting allows more of the key/fill to assert itself over the program video.



**Key Alpha** setting, when increased, increases the opacity of the key/fill. In the example to the right, progressively increasing the alpha setting increases the key/fill opacity.



When both settings are optimized, the key/fill appears consistent in opacity and free from edge distortions or graphic bleed lines appearing in the image.



**Alpha Threshold** mode setting is suited for graphic sources using black backgrounds.  
**Reverse Alpha Threshold** mode setting is suited for graphic sources using white backgrounds.



When using either alpha threshold modes, set the **Key Source** and **Fill Source** to use the same source (in this example, SDI input D).



**Figure 5 Alpha Threshold Keying Properties Controls and Examples**





**Cobalt Digital Inc.**

2406 E. University Ave.  
Urbana, IL 61802  
Voice 217.344.1243 • Fax 217.344.1245  
[www.cobaltdigital.com](http://www.cobaltdigital.com)