

AUDIO UPMIXING

Software Option

Featuring Linear Acoustic® UPMAX™ technology, the Audio Upmixing Software Option upmixes any stereo source received by a card to full 5.1-channel audio (L, R, C, LFE, Ls, Rs), thereby affording legacy stereo programming the full benefit of 5.1 channel environments.

The 5.1 upmixer can always generate a 5.1 feed from a stereo pair, or be set to look at signal levels on designated channels. Where valid 5.1 audio is present, the 5.1 upmixer allows the channels to pass unaffected. Where 5.1 audio is not

present, the 5.1 upmixer then automatically generates and routes the 5.1 audio on the designated channels.

Audio upmixing is available as an option on the Fusion3G® 9900 series, and select 9000 series cards. The software can be ordered with card purchase, or activated later using a downloadable feature key via free DashBoard™ remote control/monitoring software (no need to remove or replace card.)

FEATURES

Handles any type of stereo pair accommodated by the card

Configurable thresholds to tailor seamless automatic operation

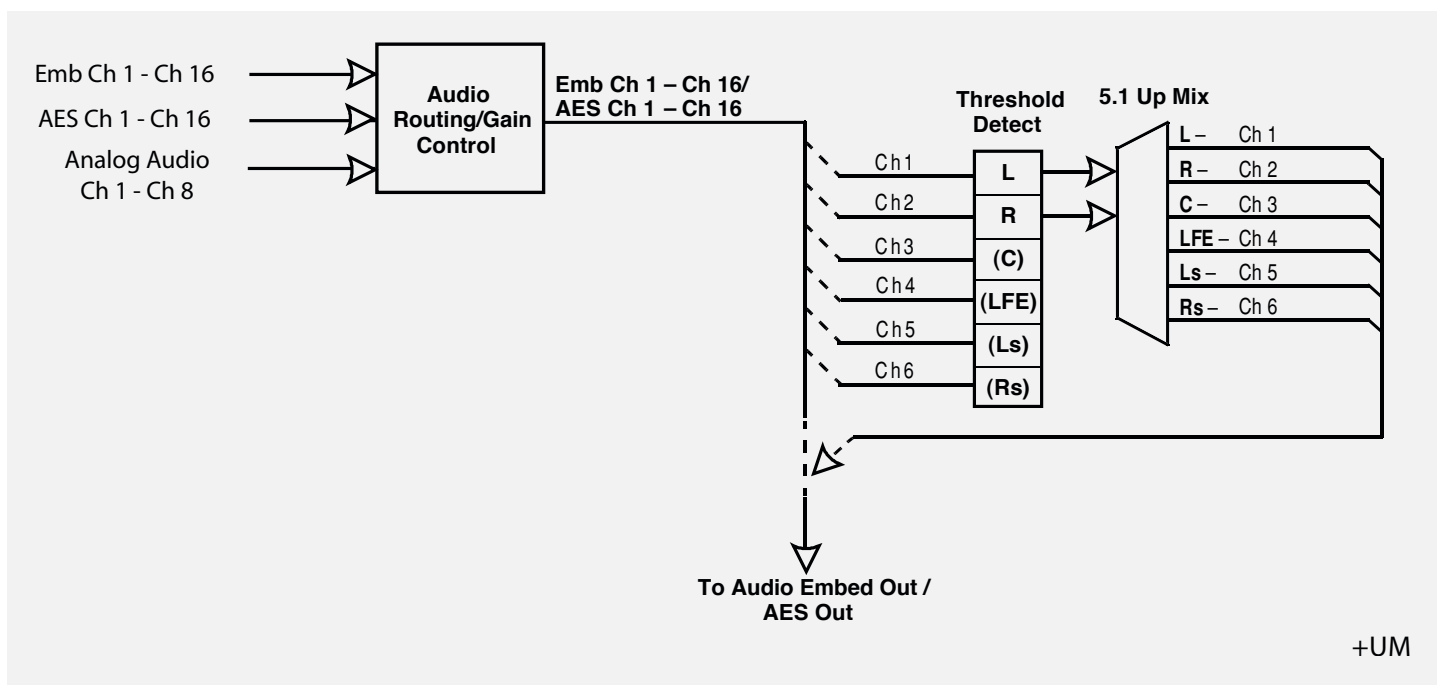

ORDERING INFORMATION

+UM Optional Linear Acoustic® Audio Upmixer (Available on Fusion3G® 9900 Series cards, and select COMPASS® 9000 Series cards. Check specific catalog pages for option availability.)

