

9910DA-AV-EQ • Analog Video Distribution Amplifier with EQ

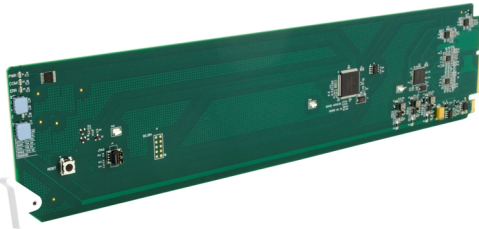

The Cobalt® 9910DA-AV-EQ Analog Video Distribution Amplifier with EQ provides 1x8 distribution with one analog input and eight 75Ω analog outputs. Card jumpers allow setting the input as differential (floating ground) or single-ended, AC or DC coupled, and Hi-Z looping input or on-card 75Ω terminated. Trim controls located on the front of the card allow EQ adjustment and gain control. The card can be accessed using DashBoard™ remote control for status monitoring. Status monitoring shows the video format of the input signal.

FEATURES

Multi-mode input provides differential or single-ended input and hi-Z looping or card-terminated operation

Signal path can be set as DC or AC coupled

User adjustable EQ and gain with easily accessible controls on front of card edge. EQ optimizes performance for input cable lengths exceeding 1000 ft (300m).

User-selectable input clamping (none, fast, or slow clamping selectable)

Remote monitoring via DashBoard™ software or OGCP-9000 Remote Control Panel. Card Status display shows presence and video format (e.g., 525i, 720p, 1080i) of input signal.

Hot-swappable

Five year warranty

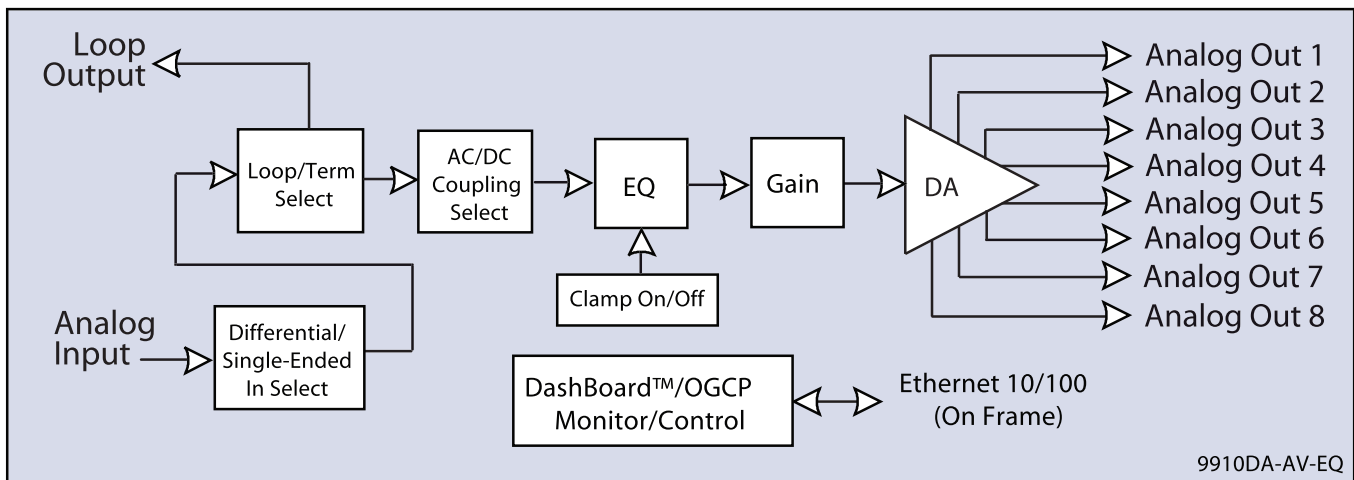

9910DA-AV-EQ

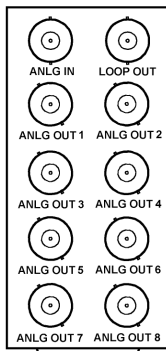

RM20-9910AV-B

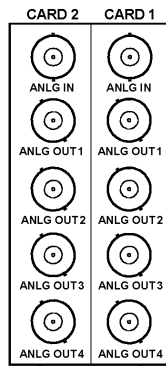

RM20-9910AV-AIS

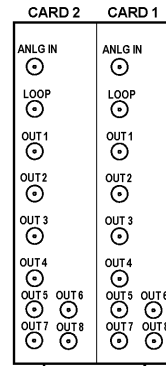

RM20-9910AV-BS-DIN  
RM20-9910AV-BS-DIN



**9910DA-AV-EQ • Analog Video Distribution Amplifier with EQ****SPECIFICATIONS**

Note: Inputs/outputs are a function in some cases of rear I/O module used.

**Power**

2 Watts

**Analog Video Input**

Number of inputs: (1)

(Compatible with any NTSC or PAL black-burst or tri-level analog video format.)

Impedance: User selectable as hi-Z looping or card-terminated 75Ω

Level: 1 Vp-p, nominal

Return Loss: 46 dB @ 3.58 MHz

Input modes: User selectable as differential/single-ended and AC or DC coupled

**Analog Video Outputs**

Number of DA outputs: up to (8)

Impedance: 75Ω

Level: 1 Vp-p, nominal

Looping Output: (1)

**Performance**

Frequency response: >0.05 dB @ 3.58 MHz

Differential Gain: >0.15% @ 3.58 MHz

Differential Phase: >0.15° @ 3.58 MHz

S/N: >60 dB; 5 MHz BW

**ORDERING INFORMATION**

**9910DA-AV-EQ** Analog Video Distribution Amplifier with EQ

**RM20-9910AV-B** 20-Slot Frame Rear I/O Module (Standard Width) (1) Analog Video Input BNC, (8) Analog DA Output BNCs, (1) Input Loop Output BNC

**RM20-9910AV-A/S** 20-Slot Frame Rear I/O Module (Split; supports 2 cards) (1) Analog Video Input BNC, (4) Analog DA Output BNCs (connections are per card)

**RM20-9910AV-B/S-DIN** 20-Slot Frame Rear I/O Module (Split; supports 2 cards) (1) Analog Video Input, (8) Analog DA Outputs, (1) Input Loop Output (connections are per card; all connectors are DIN 1.0/2.3)

**RM20-9910AV-B/S-HDBNC** 20-Slot Frame Rear I/O Module (Split; supports 2 cards) (1) Analog Video Input, (8) Analog DA Outputs, (1) Input Loop Output (connections are per card; all connectors are HD-BNC)