

# 9992-4ENC-4K-HEVC • 4K HEVC / MPEG2 Software Defined Broadcast Encoder

## with Single-Channel 4K or Quad-Channel 2K Video Paths

The Cobalt® **9992-4ENC-4K-HEVC 4K HEVC / AVC / MPEG2 Software Defined Broadcast Encoder** is a multi-channel broadcast-grade encoder designed to meet the most stringent requirements for today's broadcasters. Our HEVC video encoding technology provides a dramatic compression efficiency improvement over previous video compression standards, while also supporting existing MPEG-2 and MPEG-4 AVC. The 9992-2ENC-4K-HEVC is an industry standard openGear® card and provide an ideal platform for transitioning to state-of-the-art encoding capabilities.

### FEATURES

**Future-Proof** – Software-defined architecture supports MPEG-2, MPEG-4 AVC (H.264) and HEVC (H.265). Additional audio licenses available using optional licenses.

**Industry Standard Form-Factor** – The 9992-4ENC-4K-HEVC is offered in the industry-standard openGear format, and is compatible with existing deployed openGear frames.

**High Density** – Supports up to four independent 1080p60 input signals, or a single UHD 4Kp60 input signal. One openGear frame can support up to 10 cards, for a total of 40 HD or 10 UHD 4K channels.

**Full Audio Support** – The 9992-2ENC-4K-HEVC supports MPEG-1 Layer II, AAC-LC, HE-AAC, LPCM (SMPTE-302M) and Dolby AC-3/EAC-3 (optional license).

#### Base Unit Features –

Support for one 4K encode channel or up to four encode channels up to 1080p60

Support for MPEG-2, MPEG-4 AVC (H.264), and HEVC (H.265)

Supports all popular formats: 480i, 576i, 720p, 1080i, 1080p, 2160p

HEVC encoding

Support for 4:2:0 8-bit/10-bit encoding

Full ancillary data support

Support for 8 stereo pairs (16 audio channels) in any combination of MPEG-1 Layer II, AAC-LC, and HE-AAC (v1/v2) modes

All network protocols (RIST and SMPTE-2022 FEC available with corresponding Options)

Remote control/monitoring via Dashboard™ software

Hot-swappable

Five-year warranty

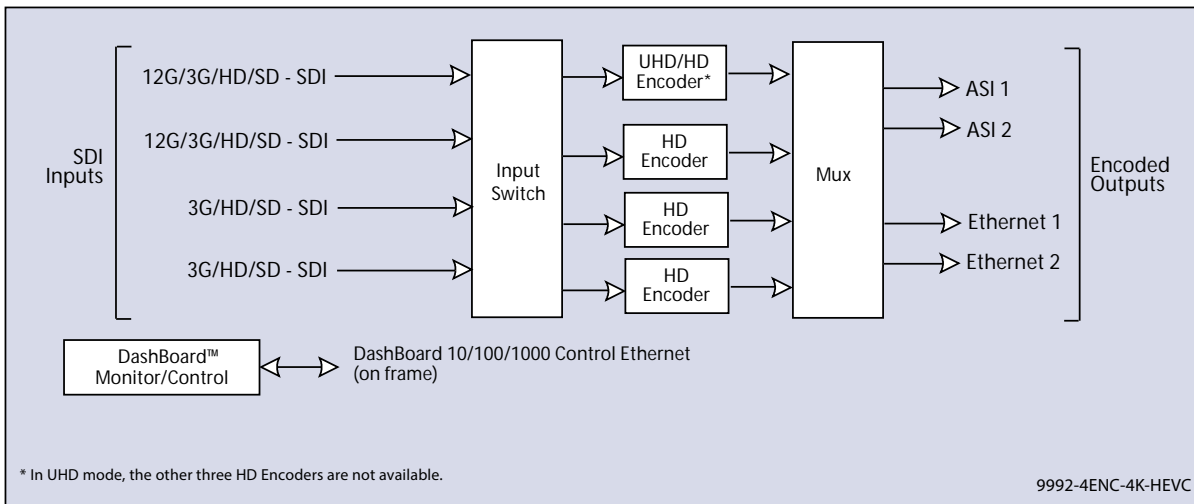

### SOFTWARE LICENSABLE OPTIONS

**+MP1L2-AAC** Additional MPEG-1 Layer II, AAC-LC, and HE-AAC audio encoding per pair. Three AAC licenses can be combined to allow one 5.1 surround encode.

**+ENC2-2.0** Dolby Digital/Dolby Digital Plus stereo audio encoding license.

**+ENC5-5.1** Dolby Digital/Dolby Digital Plus 5.1 Surround Sound audio encoding license.

**+SRT-ENC** SRT Support (per unit)

**+ULL** Adds support for HEVC Ultra-Low Latency support (per unit). Encoder latency is 10ms for the common frame rates. (In this mode, the maximum encoder capacity is one 4K or two HD streams.)

**+RIST/ARQ-ENC** RIST RTP/ARQ support (transport stream based option; only one license needed per unit).

**+RIST/ENCRP-ENC** RIST Encryption/Authentication Support (per unit). (Requires the +RIST/ARQ-ENC license to be also present on the encoder.)

**+SMPTE2022** Add SMPTE-2022 support. Provides one FEC insertion per device Ethernet port (transport stream based option; only one license needed per unit).

**+422** Adds 4:2:2 encoding support (transport stream based option; only one license needed per unit).

# 9992-4ENC-4K-HEVC • 4K HEVC / MPEG2 Software Defined Broadcast Encoder with Single-Channel 4K or Quad-Channel 2K Video Paths

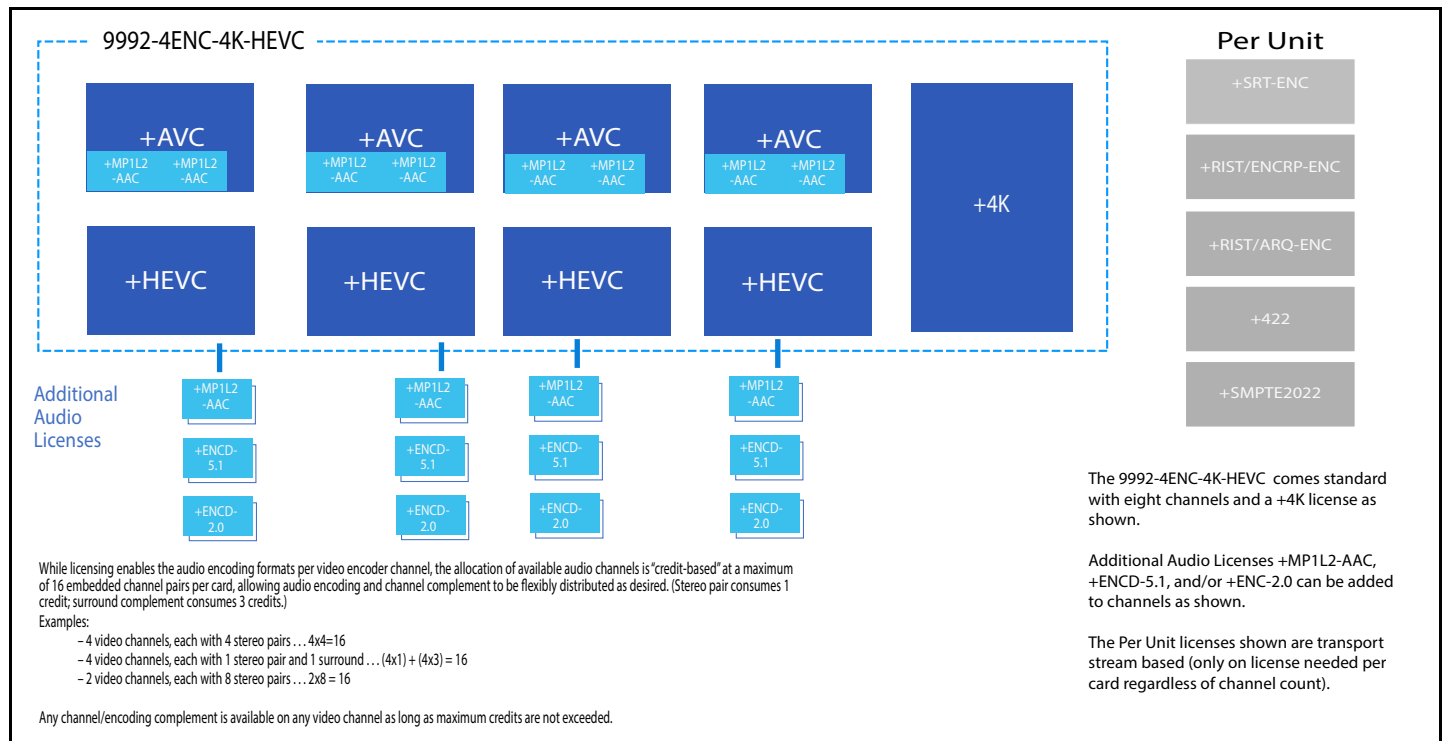

## SPECIFICATIONS

### Inputs

- (2) SDI inputs each supporting 12G-SDI, 3G-SDI, HD-SDI and SD-SDI
- (2) SDI inputs each supporting 3G-SDI, HD-SDI and SD-SDI
- Support for all standard frame rates (interlaced and progressive): 23.98, 24, 25, 29.97, 30, 50, 59.94, 60

**Note:** Although two 12G/3G/HD/SD-SDI inputs are present, only one input can be used at a time to route to the maximum-available single UHD encoder engine.  
**Note:** In UHD mode, the other three HD encoder channels are not available.

### Outputs

- (2) DVB-ASI outputs
- (2) Gigabit Ethernet ports for IP output, supporting the following protocols:
  - UDP unicast/multicast
  - RTP unicast/multicast with optional SMPTE-2022 FEC
  - HTTP Live Streaming (local or remote server)
  - RTMP (limited to H.264 only)
  - RIST for contribution over the Internet
- Integrated multiplexer creates MPTS over IP or over DVB-ASI
- Support for DVB table generation

### Video Pre-Processing

- Support for arbitrary down-scaling input video, extending down to 320x240
- Interlaced to progressive conversion
- Frame rate conversion
- Basic noise reduction filter and spatial filter
- High Dynamic Range (HDR) support.

## 9992-4ENC-4K-HEVC • 4K HEVC / MPEG2 Software Defined Broadcast Encoder with Single-Channel 4K or Quad-Channel 2K Video Paths

### Video Encoding

Encoding Standards:

- MPEG-2
- MPEG-4 AVC (H.264)
- HEVC (H.265)

Support for up to four independent 1080p60 encode sessions<sup>(1)</sup>

Support for UHD encoding in AVC and HEVC modes (Maximum resolution 4096x2160p60)

Maximum bit rates:

- UHD (4K) encoding: 150 Mb/s
- HD encoding: 40 Mb/s<sup>(2)</sup>

Support for 4:2:0 and 4:2:2 color spaces in all modes

Support for 8-bit / 10-bit encoding in all modes

Full control of GOP size and structure

Advanced compression controls available

(1) All encode sessions must use the same standard; mixed-standard encoding is not supported.

(2) The first HD channel can be as high as 150 Mb/s.

### Audio Encoding

Encoding Standards:

- MPEG-1 Layer II
- AAC-LC
- HE-AAC (v1/v2)
- Dolby AC-3
- Dolby EAC-3
- LPCM (SMPTE-302M)
- Dolby AC-3/EAC-3 pass-through support

(5.1-Surround encoding available for AAC-LC, HE-AAC, Dolby AC-3 and Dolby EAC-3; subject to licensing)

Maximum number of channels supported (subject to licensing):

- MPEG-1 Layer II: 16 stereo pairs (32 audio channels)
- Dolby AC-3: 16 stereo pairs (32 audio channels)
- Dolby EAC-3: 8 stereo pairs (16 audio channels)
- AAC-LC: 8 stereo pairs (16 audio channels)
- HE-AAC (v1/v2) 8 stereo pairs (16 audio channels)

Optional support for 5.1 Surround Sound encoding, in AAC and Dolby modes. Three stereo licenses are required to enable one 5.1 surround encode.

### Ancillary Data Support

Closed-Captioning: SMPTE-334M (EIA-608 and EIA-708 supported), Line 21 (SD sources)

OP-47/SMPTE RDD-08 teletext subtitles

AFD: SMPTE-2016, Line 20/22 WSS (SD sources)

SCTE-104 to SCTE-35 conversion

SMPTE-2038 generic ancillary data transport (timecode, KLV, etc.)

# 9992-4ENC-4K-HEVC • 4K HEVC / MPEG2 Software Defined Broadcast Encoder with Single-Channel 4K or Quad-Channel 2K Video Paths

## ORDERING INFORMATION

**9992-4ENC-4K-HEVC** 4K HEVC / AVC / MPEG2 Software Defined Broadcast Encoder with Single-Channel 4K or Quad-Channel 2K Video Paths

### Option Licenses:

- +**MP1L2-AAC** MPEG-1 Layer II, AAC-LC, and HE-AAC audio encoding license (each license adds one encoded pair)
- +**ENC2-2.0** Dolby Digital/Dolby Digital Plus stereo audio encoding license (each license adds one encoded pair)
- +**ENC2-5.1** Dolby Digital/Dolby Digital Plus 5.1 Surround Sound audio encoding license (each license adds one encoded pair)
- +**RIST/ARQ-ENC** RIST RTP/ARQ support (per unit)
- +**RIST/ENCRP-ENC** RIST Encryption/Authentication support license (per unit). (Requires the +RIST/ARQ-ENC license to also be present on the encoder.)
- +**SMPTE2022** Add SMPTE-2022 support (per unit)
- +**SRT-ENC** SRT Support (per unit)
- +**422** 4:2:2 encoding support license (per unit)
- +**ULL** HEVC Ultra-Low Latency support license (per unit)

**Note:** 9992-ENC is also available in an upgradeable basic single-channel version (up to 1080p60); upgradeable to full 9992-4ENC-4K-HEVC with progressive licensing. For info on **9992-ENC** HEVC Upgradeable AVC / MPEG2 Software Defined Broadcast Encoder model, please see 9992-ENC web page for more details.

### Rear I/O Modules:

**RM20-9992-ENC-B-HDBNC** 20-Slot Frame Rear I/O Module (Standard-Width) (2) 12G/6G/3G/HD-SD-SDI Coaxial Inputs, (2) 3G/HD/SD-SDI Coaxial Inputs, (2) ASI Coaxial Outputs, (2) GigE Ethernet Media Ports, COMM/GPIO Port (All SDI coaxial connectors HD-BNC.) (**Note:** Mates to card in **odd** slot.)

