

9992-ENC-4K-HEVC • 4K HEVC / AVC / MPEG2 Software Defined Broadcast Encoder with Single-Channel 4K or Quad-Channel 2K Video Paths

The Cobalt® **9992-ENC-4K-HEVC 4K HEVC / AVC / MPEG2 Software Defined Broadcast Encoder** is a multi-channel broadcast-grade encoder designed to meet the most stringent requirements for today's broadcasters. Our HEVC video encoding technology provides a dramatic compression efficiency improvement over previous video compression standards, while also supporting existing MPEG-2 and MPEG-4 AVC. The 9992-ENC-4K-HEVC is an industry standard openGear® card and provide an ideal platform for transitioning to state-of-the-art encoding capabilities.

FEATURES

Future-Proof – Software-defined architecture supports MPEG-2, MPEG-4 AVC (H.264) and HEVC (H.265). Additional audio licenses available using optional licenses.

Industry Standard Form-Factor – The 9992-ENC-4K-HEVC is offered in the industry-standard openGear format, and is compatible with existing deployed openGear frames.

High Density – Supports up to four independent 1080p60 input signals, or a single UHD 4Kp60 input signal. One openGear frame can support up to 10 cards, for a total of 40 HD or 10 UHD 4K channels.

Full Audio Support – The 9992-ENC-4K-HEVC supports MPEG-1 Layer II, AAC-LC, HE-AAC, LPCM (SMPTE-302M) and Dolby AC-3/EAC-3 (optional license).

Base Unit Features –

Support for one 4K encode channel or up to four encode channels up to 1080p60

Support for MPEG-2 and MPEG-4 AVC (H.264)

Supports all popular formats: 480i, 576i, 720p, 1080i, 1080pSF, 1080p

HEVC encoding

Support for 4:2:0 8-bit/10-bit encoding

Full ancillary data support

Support for 2 stereo pairs (4 audio channels) in any combination of MPEG-1 Layer II, AAC-LC, and HE-AAC (v1/v2) modes

All network protocols (RIST and SMPTE-2022 FEC available with corresponding Options)

Remote control/monitoring via Dashboard™ software

Hot-swappable

Five-year warranty

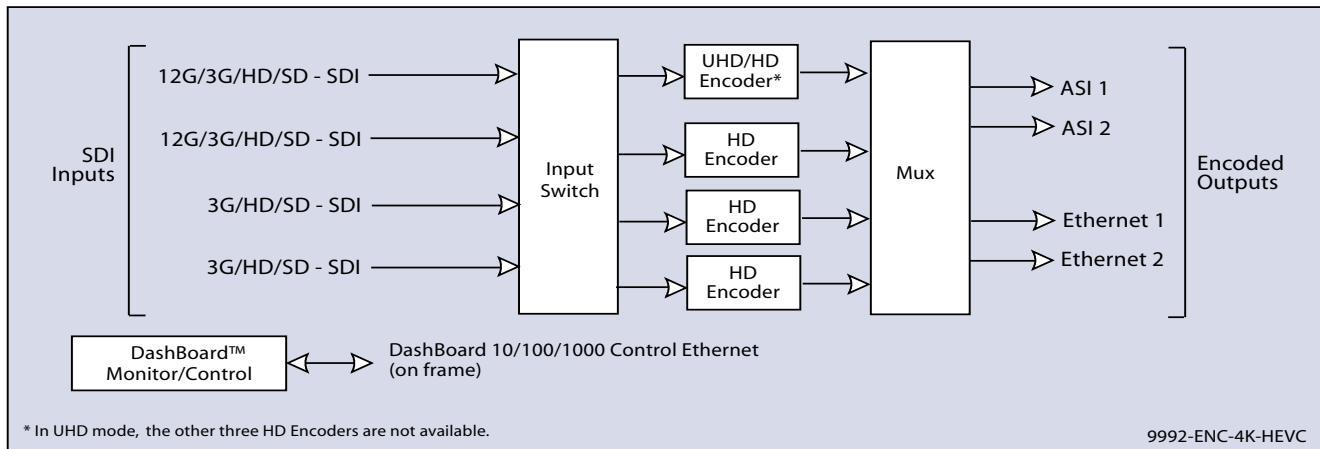

SOFTWARE LICENSABLE OPTIONS

+MP1L2-AAC Additional MPEG-1 Layer II, AAC-LC, and HE-AAC audio encoding per pair. Three AAC licenses can be combined to allow one 5.1 surround encode.

+ENC2-2.0 Dolby Digital/Dolby Digital Plus stereo audio encoding license.

+ENC5-5.1 Dolby Digital/Dolby Digital Plus 5.1 Surround Sound audio encoding license.

+SRT-ENC SRT Support (per unit)

+ULL Adds support for HEVC Ultra-Low Latency support (per unit). Encoder latency is 10ms for the common frame rates. (In this mode, the maximum encoder capacity is one 4K or two HD streams.)

+RIST/ARQ-ENC RIST RTP/ARQ support (transport stream based option; only one license needed per unit).

+RIST/ENCRP-ENC RIST Encryption/Authentication Support (per unit). (Requires the +RIST/ARQ-ENC license to be also present on the encoder.)

+SMPTE2022 Add SMPTE-2022 support. Provides one FEC insertion per device Ethernet port (transport stream based option; only one license needed per unit).

+422 Adds 4:2:2 encoding support (transport stream based option; only one license needed per unit).

9992-ENC-4K-HEVC • 4K HEVC / AVC / MPEG2 Software Defined Broadcast Encoder with Single-Channel 4K or Quad-Channel 2K Video Paths

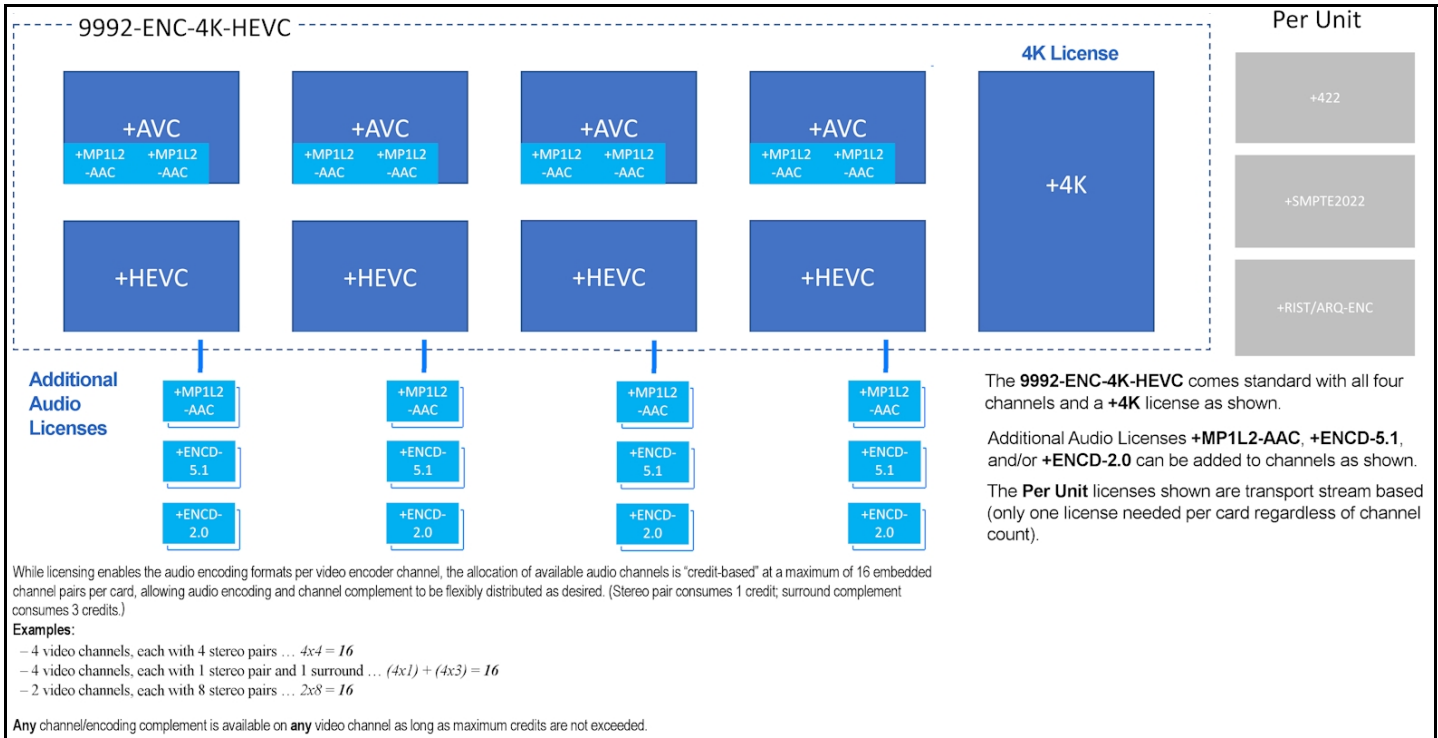

SPECIFICATIONS

Inputs

- (2) SDI inputs each supporting 12G-SDI, 3G-SDI, HD-SDI and SD-SDI
- (2) SDI inputs each supporting 3G-SDI, HD-SDI and SD-SDI
- Support for all standard frame rates (interlaced and progressive): 23.98, 24, 25, 29.97, 30, 50, 59.94, 60
- Optional support for SMPTE-2110 baseband video over IP inputs*
- * Future release availability.

Note: Although two 12G/3G/HD/SD-SDI inputs are present, only one input can be used at a time to route to the maximum-available single UHD encoder engine.

Note: In UHD mode, the other three HD encoder channels are not available.

Outputs

- (2) DVB-ASI outputs
- (2) Gigabit Ethernet ports for IP output, supporting the following protocols:
 - UDP unicast/multicast
 - RTP unicast/multicast with optional SMPTE-2022 FEC
 - HTTP Live Streaming (local or remote server)
 - RTMP (limited to H.264 only)
 - Cobalt's RTP/ARQ for contribution over the Internet
- Integrated multiplexer creates MPTS over IP or over DVB-ASI
- Support for DVB table generation
- Support for PSIP table generation*
- Optional SMPTE-2110 baseband video over IP turnaround*
- * Future release availability.

Video Pre-Processing

- Support for arbitrary down-scaling input video, extending down to 320x240
- Support for up-scaling input video*
- Interlaced to progressive conversion
- Progressive to interlaced conversion*
- Frame rate conversion
- Basic noise reduction filter and spatial filter
- Enhanced pre-processing filters*
- High Dynamic Range (HDR) support
- * Future release availability.

9992-ENC-4K-HEVC • 4K HEVC / AVC / MPEG2 Software Defined Broadcast Encoder with Single-Channel 4K or Quad-Channel 2K Video Paths

Video Encoding

Encoding Standards:

- MPEG-2
- MPEG-4 AVC (H.264)
- HEVC (H.265)

Support for up to four independent 1080p60 encode sessions⁽¹⁾

Support for UHD encoding in AVC and HEVC modes (Maximum resolution 4096x2160p60)

Maximum bit rates:

- UHD (4K) encoding: 150 Mb/s
- HD encoding: 40 Mb/s⁽²⁾

Support for 4:2:0 and 4:2:2 color spaces in all modes

Support for 8-bit / 10-bit encoding in all modes

Full control of GOP size and structure

Advanced compression controls available

(1) All encode sessions must use the same standard; mixed-standard encoding is not supported.

(2) The first HD channel can be as high as 150 Mb/s.

Audio Encoding

Encoding Standards:

- MPEG-1 Layer II
- AAC-LC
- HE-AAC (v1/v2)
- Dolby AC-3
- Dolby EAC-3
- LPCM (SMPTE-302M)
- Dolby AC-3/EAC-3 pass-through support

(5.1-Surround encoding available for AAC-LC, HE-AAC, Dolby AC-3 and Dolby EAC-3; subject to licensing)

Maximum number of channels supported (subject to licensing):

- MPEG-1 Layer II: 16 stereo pairs (32 audio channels)
- Dolby AC-3: 16 stereo pairs (32 audio channels)
- Dolby EAC-3: 8 stereo pairs (16 audio channels)
- AAC-LC: 8 stereo pairs (16 audio channels)
- HE-AAC (v1/v2) 8 stereo pairs (16 audio channels)

Optional support for 5.1 Surround Sound encoding, in AAC and Dolby modes. Three stereo licenses are required to enable one 5.1 surround encode.

Optional audio module: increases the capacity to 32 stereo pairs (64 audio channels), allowing full 16-channel support for the four HD inputs, in all compression modes*

* Future release availability.

Ancillary Data Support

Closed-Captioning: SMPTE-334M (EIA-608 and EIA-708 supported), Line 21 (SD sources)

OP-47/SMPTE RDD-08 teletext subtitles*

AFD: SMPTE-2016, Line 20/22 WSS (SD sources)

SCTE-104 to SCTE-35 conversion

SMPTE-2038 generic ancillary data transport (timecode, KLV, etc.)

* Future release availability.

9992-ENC-4K-HEVC • 4K HEVC / AVC / MPEG2 Software Defined Broadcast Encoder with Single-Channel 4K or Quad-Channel 2K Video Paths

ORDERING INFORMATION

9992-ENC-4K-HEVC 4K HEVC / AVC / MPEG2 Software Defined Broadcast Encoder with Single-Channel 4K or Quad-Channel 2K Video Paths

Option Licenses:

+MP1L2-AAC MPEG-1 Layer II, AAC-LC, and HE-AAC audio encoding license (each license adds one encoded pair)

+ENC2-2.0 Dolby Digital/Dolby Digital Plus stereo audio encoding license (each license adds one encoded pair)

+ENC2-5.1 Dolby Digital/Dolby Digital Plus 5.1 Surround Sound audio encoding license (each license adds one encoded pair)

+RIST/ARQ-ENC RIST RTP/ARQ support (per unit)

+RIST/ENCRP-ENC RIST Encryption/Authentication support license (per unit). (Requires the +RIST/ARQ-ENC license to also be present on the encoder.)

+SMPTE2022 Add SMPTE-2022 support (per unit)

+SRT-ENC SRT Support (per unit)

+422 4:2:2 encoding support license (per unit)

+ULL HEVC Ultra-Low Latency support license (per unit)

Note: 9992-ENC is also available in an upgradeable basic single-channel version (up to 1080p60); upgradeable to full 9992-ENC-4K-HEVC with progressive licensing. For info on **9992-ENC** HEVC Upgradeable AVC / MPEG2 Software Defined Broadcast Encoder model, please see 9992-ENC web page for more details.

Rear I/O Modules:

RM20-9992-ENC-B-HDBNC 20-Slot Frame Rear I/O Module (Standard-Width) (2) 12G/6G/3G/HD-SD-SDI Coaxial Inputs, (2) 3G/HD/SD-SDI Coaxial Inputs, (2) ASI Coaxial Outputs, (2) GigE Ethernet Media Ports, COMM/GPIO Port (All SDI coaxial connectors HD-BNC.) (**Note:** Mates to card in **odd** slot.)

