

BBG-1002-UDX-DSP • 3G/HD/SD-SDI Standalone Up-Down-Cross Converter/Frame Sync/ Audio Embed-De-Embed with DSP Audio Options Support



The Cobalt® **BBG-1002-UDX-DSP 3G/HD/SD-SDI Standalone Up-Down-Cross Converter/Frame Sync/Audio Embed-De-Embed with DSP Audio Options Support** provides a high-density standalone solution that offers unprecedented multi-input support and flexibility. The BBG-1002-UDX-DSP offers a DSP-based platform that supports multiple **+DSP** audio options. When optioned with various audio processing options, the DSP-based processing core (which supports numerous simultaneous processing engines) uses license “credits” which allows flexible tailoring of multiple proc function instances. The BBG-1002-UDX-DSP provides much more flexibility than other audio processors that used fixed processing assets (for example, this flexibility allows “trading” credits for more Dolby encoders while backing out of loudness processors or other engine assets).

Audio proc **+DSP** options include Dolby® Real-Time Loudness Leveling automatic loudness processing, Dolby® encode/decode, and Linear Acoustic® UPMAX™ automatic upmixing. DSP options can be ordered with new-card purchase, or field-installed as software option upgrades without disconnecting the unit. Included as standard features are downmixing, flex mixing, and full AES and balanced analog audio embed/de-embed. Also included standard is bulk

and per-channel audio delay controls that easily address lip-sync issues. Option **+TTS** provides high-quality Text-To-Speech synthesis, directly converting EAS text to digital audio speech with no baseband signal breakouts or add-ons. Quality Check option **+QC** checks for and acts upon user-configurable criteria such as black/frozen frame, audio silence or CC absence.

The up/down/cross convert scaler is specifically designed for broadcast video progressive and interlaced formats, with full ARC control suitable for conversions to or from 4:3 and 16:9 aspect ratios. 3:2 pulldown optimization allows A-frame to use alignment correlated to received timecode or 6 Hz external input over GPI. AFD processing can detect an incoming AFD code and correspondingly set scaling to track with AFD. The BBG-1002-UDX-DSP also provides analog CVBS video inputs and outputs, and AES/analog audio embedding and de-embedding.

Preset save/load allows saving custom settings while allowing one-button revert to factory settings. Layered presets allow invoking changes related only to a specific area of concern (audio routing, for example) while not changing any other processing settings or aspects. The BBG-1002-UDX-DSP can be remote-controlled using DashBoard™. GPIO allows direct input routing control and status monitoring. The compact standalone form factor allows desktop usage, as well as the 1/3-rack size of the BBG-1002-UDX-DSP allowing 3 units to be installed in a 1RU space (an optional mounting tray is available that provides secure mounting of the units to a standard 19” frame).

FEATURES

DSP-based platform supports multiple audio DSP options, with multiple instances available using allocatable license “credits” – our largest DSP capacity

Dolby encoding/decoding, loudness processing, and upmixing DSP audio options available

Auto Adjust feature helps assure lip sync by assessing and alerting where DSP processing requires matching video delay

Full audio crosspoint with 5.1-to-stereo downmix (standard) available for all audio outputs

Supports all popular formats: 480i, 576i, 720p, 1080i, 1080pSF, 1080p

CVBS analog video I/O and analog/AES embed / de-embed available

Moving-box/ motion insertion enable serves as a dynamic raster confidence check even in cases where the input video image is static. Dual-string character/timecode burn-in.

Advanced audio processing allows routing, gain, smooth delay, and flexible mixing as standard features

Option **+TTS** provides Text-To-Speech synthesis, directly converting EAS text to high-quality digital audio speech with no baseband signal breakouts or add-on units

Up/Down/Cross Conversion with user and AFD, VI, and WSS ARC specifically tailored for broadcast video

Supports import of user trouble slate graphic file for LOS failover insertion

3:2 pulldown optimization allows A-frame alignment correlated to received timecode or 6 Hz external input over GPI

Option **+ANC** adds full user VANC/HANC packet insertion/extraction access to DID/SDID ancillary data such as camera PTZ, SCTE 104, closed captioning, and other specialized user payloads. SMPTE 337 embed/ de-embed allows serial user data to be embedded and de-embedded over unused embedded audio pairs.

Compact footprint – up to 3 units in a 1RU space. Optional tray provides secure captive-fastener mounting of 3 units in a 1RU tray.

Remote control/monitoring via DashBoard™ software, OGCP-9000 Remote Control Panel, or Web Browser User Interface

Five year warranty

BBG-1002-UDX-DSP • 3G/HD/SD-SDI Standalone Up-Down-Cross Converter/Frame Sync/ Audio Embed-De-Embed with DSP Audio Options Support

OPTIONS

Dolby® Real-Time Loudness Levelling Automatic Loudness Processing Options (**+DSP-RTLL**) – Provides advanced loudness processing with comprehensive parametric controls. Available as surround 5.1 and stereo 2.0. (See Ordering Information for full details.)

Dolby® Encoder Options (**+DSP-ENCD**) – Available as 5.1 and 2.0 Dolby Digital and Digital Plus Encode. (See Ordering Information for full details.)

Dolby® Decoder Options (**+DSP-DEC**) – Provides Dolby Digital, Digital Plus, and E Decode.

Linear Acoustic® UPMAX™ Upmixing (**+DSP-UPMIX-LA**) – Provides automatic 2.0-to-5.1 Linear Acoustic® UPMAX™ upmixing.

Linear Acoustic® AEROMAX™ Loudness Processor Options (**+DSP-LP**) – Available as surround 5.1 and stereo 2.0. (See Ordering Information for full details.)

Audyne ITU Loudness Leveler Options (**+DSP-ITU**) – Available as surround 5.1 and stereo 2.0. (See Ordering Information for full details.)

Linear Frame Rate Conversion (**+FRC**) – Provides comprehensive high-quality standards conversion utilizing Cobalt's linear frame rate conversion to convert between virtually any SD/HD/3G format.

Quality Check Option (**+QC**) – Provides failover, alert, or user presets action on criteria such as black/frozen frame, audio silence, and CC absence.

Clean & Quiet Switching Option (**+CQS**) – Provides automatic audio ramp-down and up during input switching events.

Text-To-Speech Option (**+TTS**) – Provides Text-To-Speech synthesis, directly converting EAS text to digital audio speech with no baseband signal breakouts or add-ons. High-quality Text-To-Speech from Acapela Group.

Color Correction (**+COLOR**) – Full RGB color corrector (offset, gain, gamma) with extended YCbCr proc controls with white/black hard clip, white soft clip, and saturation clip.

SCTE 104 Insertion (**+SCTE104**) – Provides generation/insertion of SCTE 104 data into baseband SDI. Message send can be triggered from automation GPI or other modes. Full control of splice start, end, and cancel as well as pre-roll offsets.

Trouble Slate Import (**+T-SLATE**) – Allows uploading of up to three different user trouble slate graphic file to card, with automated insertion controlled by GPI or other events.

Logo Insertion (**+LOGO**) – Allows uploading of user logo graphic file to card, with automated insertion controlled by GPI or other events.

Emergency Alert System Text Crawl Generation (**+EAS**) – Provides a single-device solution for keying Emergency Alert System (EAS) text crawls in the active video and inserting station identification logos. Compatible with Sage™, Dasdec™, and other EAS crawl generators, with automated control insertion via presence of crawl data or GPI.

Add Extended Delay Option (**+DLY**)

Audio LTC I/O (**+LTC**)

Ancillary Data Processor Option (**+ANC**) – Provides full user VANC/HANC packet insertion/extraction access to DID/SDID ancillary data, with insert/extract to and from IP and GPIO external interfaces.

SCTE104 Frame-Accurate SCTE Trigger Insertion Option (**+SCTE104-FAST**) Provides deterministic, frame-accurate Digital Program Insertion (DPI) message embedding into SDI, optimizing it for automatic dissemination to CDN and VOD systems.

1RU Mounting Tray (supports 3 units) (**BBG-1000-TRAY**)

Redundant Power Supply Module (**BBG-1000-PS**)

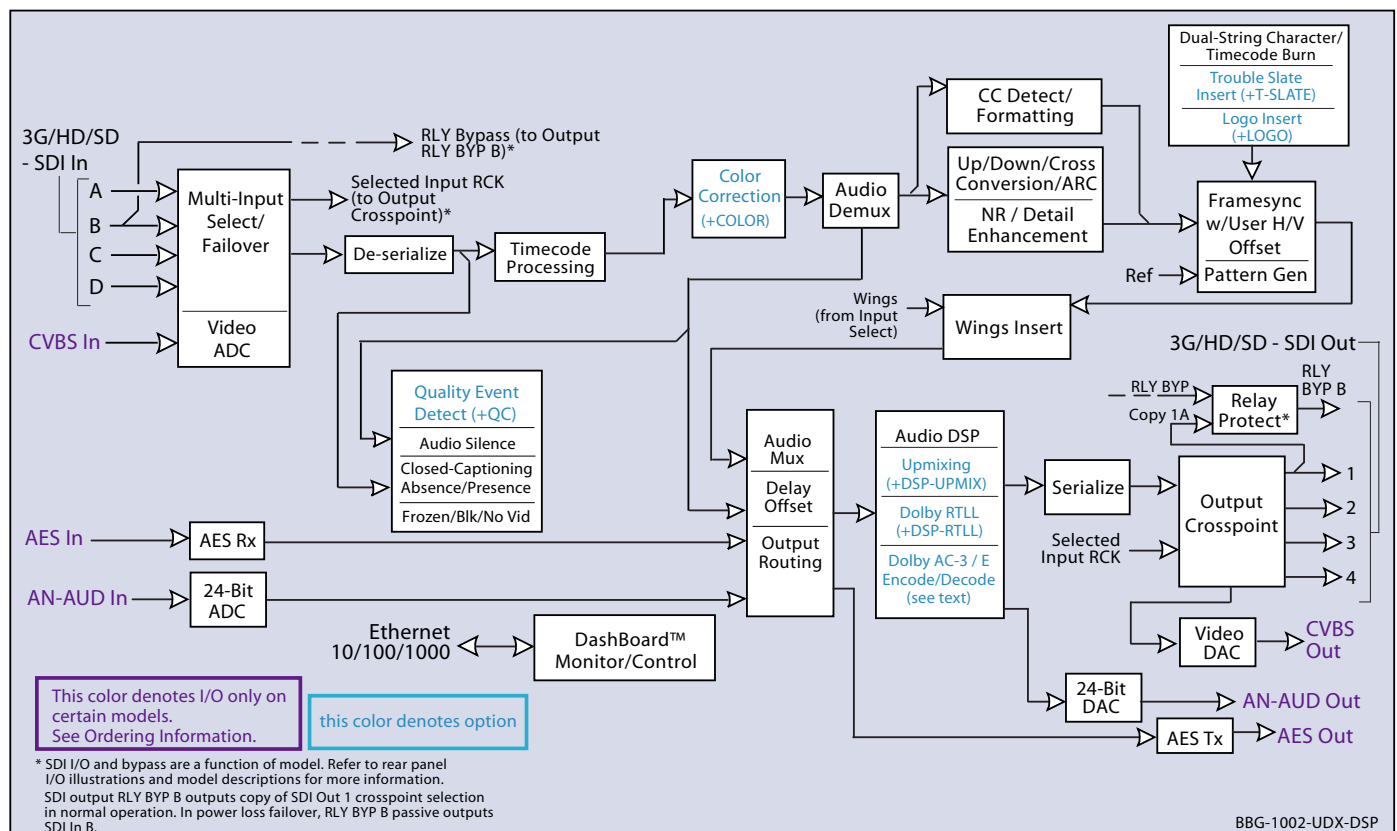

BBG-1002-UDX-DSP

BBG-1002-UDX-DSP • 3G/HD/SD-SDI Standalone Up-Down-Cross Converter/Frame Sync/ Audio Embed-De-Embed with DSP Audio Options Support

SPECIFICATIONS

Note: Inputs/outputs are a function in some cases of model. See rear panel illustrations for I/O complements offered.

Power

24 Watts (includes +DSP options). Power supplied by 12VDC AC adapter, universal input (included).

SDI Input/Outputs

Up to (4) 75Ω BNC inputs
 Up to (4) 75Ω BNC outputs (selectable as processed SDI IN or IN RCK)
 SDI Formats Supported: SMPTE 259M, SMPTE 292M, SMPTE 424M
 SDI Receive Cable Length: 3G/HD/SD: 120/180/320 m (Belden 1694A)
 SDI Return Loss: >15 dB up to 1.485 GHz; >10 dB up to 2.970 GHz
 SDI Alignment Jitter: 3G/HD/SD: < 0.3/0.2/0.2 UI
 Timing Jitter: 3G/HD/SD: < 2.0/1.0/0.2 UI
 Minimum Latency (frame sync and scaler disabled): SD: 127 pixels (9.4 us); 720p: 330 pixels (4.45 us); 1080i: 271 pixels (3.65 us); 1080p: 361 pixels (2.43 us)

CVBS Video Input/Outputs

(1) 75Ω BNC input
 (1) 75Ω BNC output. CVBS can be upconverted to any supported SDI format; all formats can be downconverted to CVBS.
 ADC resolution/sampling: 10-bit; 4x oversampling
 DAC resolution/sampling: 10-bit; 16x oversampling
 Y/C separation: 4 line Adaptive Comb Filter
 Freq. Response: ± 0.25 dB to 5.5 MHz
 SNR: > 50 dB to 5.5 MHz (unweighted)
 Differential Phase: < 1 degree
 Differential Gain: < 1%
 Nonlinearity < 1%

Discrete Audio Input/Outputs

AES-3id 75Ω inputs (8 pair (16-Ch) max)
 AES-3id 75Ω outputs (8 pair (16-Ch) max)
 Input AES SRC Range: 32 to 96 kHz
 Balanced analog audio inputs (4-Ch max)
 Balanced analog audio outputs (4-Ch max)
 (I/O conforms to 0 dBFS = +24 dBu)
 Analog Output Impedance: < 50 Ω
 Analog Reference Level: -20 dBFS
 Analog Nominal Level: +4 dBu
 Analog Max Output Level: +24 dBu (0 dBFS)
 Analog Freq. Response: ±0.2 dB (20 Hz to 20 kHz)
 Analog SNR: 115 dB (A weighted)
 Analog THD+N: -96 dB (20 Hz to 10 kHz)
 Analog Crosstalk: -106 dB (20 Hz to 20 kHz)

Frame Sync Audio/Video Delay

Max offset: 20 frames
 Latency (min): 1 frame
 Option +DLY Delay (3G/HD/SD): >800 msec / >1580 msec / >9000 msec

ARC

ARC manually configurable (custom) or automatic triggering in full compliance/conformity with AFD (SMPTE 2016), VI (RP186), and WSS triggering.

User Audio Delay Offset from Video

Bulk delay control: -33 msec to +3000 msec.
 Per-channel delay controls: -800 msec to +800 msec

Timecode/Text Insertion/Burn-In

Burn-in and embedded video output timecode selected via user controls from input video SMPTE embedded timecode and/or audio LTC. Burn-in enable/disable user controls. Configurable for burn-in string of seconds, seconds:frames, seconds:frames:field. User controls for text size and H/V position. (2) independent text strings supported. Independent insertions controls for enable/disable and enable upon LOS. User controls for text size and H/V position

GPIO/COMM

(2) GPI configurable to select input routing. (2) GPO configurable to invoke upon input selected. RS-232/485 comm port. All connections via rear panel RJ-45 GPIO/COMM jack (where equipped).

Control/Monitor Interface

Front panel network setup. DashBoard remote control via 10/100/1000 Ethernet port.

Frame Reference Input

Looping 2-BNC connection. SMPTE 170M/318M "Black Burst", SMPTE 274M/296M "Tri-Level". Return Loss: >35 dB up to 5.75 MHz

Physical

Dimensions (WxHxD): 5.7 x 1.4 x 14.7 in (14.5 x 3.5 x 37.3 cm) Dimensions include connector projections. Weight: 6 lb (2.8 kg)

BBG-1002-UDX-DSP • 3G/HD/SD-SDI Standalone Up-Down-Cross Converter/Frame Sync/ Audio Embed-De-Embed with DSP Audio Options Support

ORDERING INFORMATION

BBG-1002-UDX-DSP 3G/HD/SD-SDI Standalone Up-Down-Cross Converter/Frame Sync/Audio Embed-De-Embed with DSP Audio Options Support with (4) 3G/HD/SD-SDI Input BNCs w/ (1) Relay Protect, (4) 3G/HD/SDI Output BNCs, GPIO/COMM (RJ-45 connector), (1) Gigabit Ethernet, Looping Reference and Redundant DC Power Inputs (includes one BBG-1000-PS Power Supply)

BBG-1002-UDX-DSP-B 3G/HD/SD-SDI Standalone Up-Down-Cross Converter/Frame Sync/Audio Embed-De-Embed with DSP Audio Options Support with (1) 3G/HD/SD-SDI Input BNC, (1) CVBS Input BNC, (1) AES Input BNC, (2) Balanced Analog Inputs, (1) 3G/HD/SDI Output BNC, (1) CVBS Output BNC, (1) AES Output BNC, (2) Balanced Analog Audio Outputs, (1) Gigabit Ethernet, Looping Reference I/O and Redundant DC Power Inputs (includes one BBG-1000-PS Power Supply)

BBG-1002-UDX-DSP-C 3G/HD/SD-SDI Standalone Up-Down-Cross Converter/Frame Sync/Audio Embed-De-Embed with DSP Audio Options Support with (1) 3G/HD/SD-SDI Input BNC, (1) CVBS Video In BNC, (2) AES In BNCs, (2) Balanced Analog Audio Inputs, (1) 3G/HD/SDI Output BNC, (1) CVBS Video Out BNC, (2) AES Out BNCs, (2) Balanced Analog Audio Outputs, (1) Gigabit Ethernet, Looping Reference I/O and Redundant DC Power Inputs (includes one BBG-1000-PS Power Supply)

BBG-1002-UDX-DSP-D-DIN 3G/HD/SD-SDI Standalone Up-Down-Cross Converter/Frame Sync/Audio Embed-De-Embed with DSP Audio Options Support with (4) 3G/HD/SD-SDI Inputs, (2) Balanced Analog Audio In, (6) AES Inputs, (4) 3G/HD/SDI Outputs w/ (1) relay protect, (4) AES Outputs, GPIO/COMM (RJ-45 connector) (1) Gigabit Ethernet, Looping Reference and Redundant DC Power Inputs (includes one BBG-1000-PS Power Supply; All coaxial connectors DIN 1.0/2.3)

BBG-1002-UDX-DSP-D-HDBNC 3G/HD/SD-SDI Standalone Up-Down-Cross Converter/Frame Sync/Audio Embed-De-Embed with DSP Audio Options Support with (4) 3G/HD/SD-SDI Inputs, (2) Balanced Analog Audio In, (6) AES Inputs, (4) 3G/HD/SDI Outputs w/ (1) relay protect, (4) AES Outputs, GPIO/COMM (RJ-45 connector) (1) Gigabit Ethernet, Looping Reference and Redundant DC Power Inputs (includes one BBG-1000-PS Power Supply; all coaxial connectors HDBNC)

Options and Accessories:

+DSP-RTLL-5.1 Dolby® RTLL™ 5.1-Channel Loudness Processor Option

+DSP-RTLL-2.0 Dolby® RTLL™ Stereo Loudness Processor Option

+DSP-ENCD-5.1 Dolby® Digital/Digital Plus 5.1 Encoder

+DSP-ENCD-2.0 Dolby® Digital/Digital Plus 2.0 Encoder

+DSP-DEC Dolby® Decoder

+DSP-UPMIX-LA Linear Acoustic® UPMAX™ 2.0-to-5.1 Upmixer

+DSP-LP-5.1 Linear Acoustic® AEROMAX™ 5.1-Channel Loudness Processor Option

+DSP-LP-2.0 Linear Acoustic® AEROMAX™ 2-Channel Loudness Processor Option

+DSP-ITU-5.1 Audyne ITU 5.1-Channel Loudness Leveler Option (1)

+DSP-ITU-2.0 Audyne ITU 2.0-Channel Loudness Leveler Option (1)

+ANC Ancillary Data Processor Option

+COLOR Color Correction Option

+T-SLATE User Trouble Slate Graphic Import Option

+LOGO Logo Insertion Option

+FRC Linear Frame Rate Conversion Option

+SCTE104 SCTE 104 Insertion Option

+SCTE104-FAST Frame-Accurate SCTE 104 Trigger Insertion Option

+DLY Extended Frame Sync Delay Option

+LTC Audio LTC I/O Option

+CQS Clean & Quiet Switching Option

+QC Quality Check Option

+TTS Text-To-Speech Option (Acapela Text-To-Speech from Acapela Group™. Installation requires option upload and installation of speech library SD memory card onto host card. Pre-loaded SD card and instructions provided.)

+2L-SPAN Add Spanish-language upgrade (add-on to option +TTS; option +TTS required)

+EAS Emergency Alert System Text Crawl Generation Option

BBG-1000-PS Redundant Power Supply Module

BBG-1000-TRAY 1RU Mounting Tray (supports 3 units)

(1) Manufactured under license from Audyne Inc.

**BBG-1002-UDX-DSP • 3G/HD/SD-SDI Standalone Up-Down-Cross Converter/Frame Sync/
Audio Embed-De-Embed with DSP Audio Options Support**

Rear Panel

