

## BBG-1002-UDX • 3G/HD/SD-SDI Standalone Up-Down-Cross Converter/Frame Sync/ Audio Embed-De-Embed with Multi-Input Auto-Changeover



The Cobalt® **BBG-1002-UDX 3G/HD/SD-SDI Standalone Up-Down-Cross Converter/Frame Sync/Audio Embed-De-Embed with Multi-Input Auto-Changeover** provides a high-density standalone unit that offers unprecedented multi-input support and flexibility.

Option +TTS provides high-quality Text-To-Speech synthesis, directly converting EAS text to digital audio speech with no baseband signal breakouts or add-ons. It interfaces with industry standard Windows Share folder systems to receive non-proprietary text, XML, or similar plain text files, and converts and inserts realistic human-voice audio into user-configured audio channels. Option +EAS provides EAS crawl burn-ins directly from industry standard EAS devices such as Sage™.

Quality Check option +QC allows failover to alternate inputs based on user-configurable subjective criteria such as black/frozen frame. Two discrete character burn strings can be inserted on output video, with each string inserted as static text and/or insert only upon LOS. With option +T-SLATE, import of user trouble slate graphics is also supported

in addition to standard test pattern insert as an input LOS/quality event marker. A moving-box insertion can be enabled to serve as a dynamic raster confidence check even when the input video image is static. Included standard is closed captioning absence/presence detection for CEA 608/708 and line 21 SD closed captioning.

The up/down/cross convert scaler is specifically designed for broadcast video progressive and interlaced formats, with full ARC control suitable for conversions to or from 4:3 and 16:9 aspect ratios. 3:2 pulldown optimization allows A-frame to use alignment correlated to received timecode or 6 Hz external input over GPI. AFD processing can detect an incoming AFD code and correspondingly set scaling to track with AFD. Linear Frame Rate Conversion option +FRC allows conversion between virtually any SD/HD/3G format – from 525/625i to 1080p and anything in-between – with conversion to and from NTSC and PAL available for all input and output formats. The BBG-1002-UDX also provides analog CVBS video inputs and outputs, and AES/analog audio embedding and de-embedding.

Preset save/load allows saving custom settings while allowing one-button revert to factory settings. Layered presets allow invoking changes related only to a specific area of concern (audio routing, for example) while not changing any other processing settings or aspects. The BBG-1002-UDX can be remote-controlled using DashBoard™. GPIO allows direct input routing control and status monitoring. The compact standalone form factor allows desktop usage, as well as the 1/3-rack size of the BBG-1002-UDX allowing 3 units to be installed in a 1RU space (an optional mounting tray is available that provides secure mounting of the units to a standard 19" frame).

### FEATURES

Multi-input, with manual selection or intelligent Auto-Changeover failover

Closed-captioning absence detection and flagging, with GPIO, automated alert email, go-to user preset, or other actions

Auto-Changeover can be set to invoke failover for basic input loss. Quality Check option (+QC) provides failover on subjective criteria such as black/frozen frame or audio silence. Threshold and hold-off are user configurable.

Moving-box/motion insertion enable serves as a dynamic raster confidence check even in cases where the input video image is static

Dual independent burn-in text string insertion allows condition-based insertion (such as basic ID text for valid input and different text message for failover conditions)

Frame Sync with full H/V offset and manual/LOS video pattern generator

3:2 pulldown optimization allows A-frame alignment correlated to received timecode or 6 Hz external input over GPI

Option +TTS provides Text-To-Speech synthesis, directly converting EAS text to high-quality digital audio speech with no baseband signal breakouts or add-on units

Up/Down/Cross Conversion with user and AFD, VI, and WSS ARC specifically tailored for broadcast video

Supports import of user trouble slate graphic file for LOS failover insertion

Timecode processing can prioritize, filter for, and convert between specific SMPTE embedded-video or audio LTC, with output/burn-in timecode using selected format

Full audio crosspoint with delay control and 5.1-to-stereo downmix available for all audio outputs

CVBS analog video I/O and analog/AES embed / de-embed available

Video options include CGMS support, color correction, and keying

Option +ANC adds full user VANC/HANC packet insertion/extraction access to DID/SDID ancillary data such as camera PTZ, SCTE 104, closed captioning, and other specialized user payloads. Multi-mode setup includes Bridge mode (device internal path with scaler bypass bridging) or Insert/Extract modes for insert/extract to or from IP/serial external interfaces. SMPTE 337 embed/de-embed allows serial user data to be embedded and de-embedded over unused embedded audio pairs.

Supports import of user trouble slate graphic file for LOS failover insertion

Compact footprint – up to 3 units in a 1RU space. Optional tray provides secure captive-fastener mounting of 3 units in a 1RU tray.

Remote control/monitoring via DashBoard™ software, OGCP-9000 Remote Control Panel, or Web Browser User Interface

Five year warranty



**BBG-1002-UDX • 3G/HD/SD-SDI Standalone Up-Down-Cross Converter/Frame Sync/  
Audio Embed-De-Embed with Multi-Input Auto-Changeover**

**OPTIONS**

**Quality Check (+QC)** – Provides failover, alert, or user presets action on criteria such as black/frozen frame, audio silence, and CC absence.

**Key/Fill Keyer (+KEYER)** – Provides keying using independent SDI inputs for key and fill signals. A separate preview SDI output is provided for observing key results before applying to program video output. Alpha Threshold mode allows full-color key/fill using low-cost PC-based graphics host where the same signal provides a shared key/fill input.

**Extended Frame Sync Delay (+DLY)** – Increases frame buffer to provide adjustable audio/video delay buffer capacity to over 9 seconds for SD video, 1.5 seconds for HD video, or 0.8 seconds for 3G video.

**Trouble Slate Import (+T-SLATE)** – Allows uploading of up to three different user trouble slate graphic file to the BBG unit, with automated insertion controlled by GPI or other events.

**SCTE104 Frame-Accurate SCITE Trigger Insertion Option (+SCTE104-FAST)** – Uses Time Stamp data derived from broadcast automation to provide deterministic, frame-accurate Digital Program Insertion (DPI) message embedding into SDI. The linear channel is output with precise metadata marking the beginning and ending of each program and commercial segment, optimizing it for automatic dissemination to CDN and VOD systems.

**Linear Frame Rate Conversion (+FRC)** – Provides comprehensive high-quality standards conversion utilizing Cobalt's linear frame rate conversion to convert between virtually any SD/HD/3G format.

**Color Correction (+COLOR)** – Full RGB color corrector (offset, gain, gamma) with extended YCbCr proc controls with white hard clip, white soft clip, black hard clip, and saturation clip.

**SCTE 104 Insertion (+SCTE104)** – Provides generation/insertion of SCTE 104 data into baseband SDI. Message send can be triggered from automation GPI or other modes. Full control of splice start, end, and cancel as well as pre-roll offsets.

**Ancillary Data Processor (+ANC)**. Provides full user VANC/HANC packet insertion/extraction access to DID/SDID ancillary data, with insert/extract to and from IP, RS-232/RS-422 serial, and GPIO external interfaces. Bridge mode can be set to preserve special/custom ANC packages when scaler is enabled. SMPTE 337 embed/de-embed allows serial user data to be embedded and de-embedded over unused embedded audio pairs.

**Logo Insertion Option (+LOGO)** – Allows uploading of user logo graphic file to BBG unit, with automated insertion controlled by GPI or other events.

**Text-To-Speech (+TTS)** – Provides Text-To-Speech synthesis, directly converting EAS text to digital audio speech with no baseband signal breakouts or add-ons. High-quality Text-To-Speech from Acapela Group.

**Emergency Alert System Text Crawl Generation (+EAS)** – Provides a single-device solution for keying Emergency Alert System (EAS) text crawls in the active video and inserting station identification logos. Compatible with Sage™, Dasdec™, and other EAS crawl generators, with automated control insertion via presence of crawl data or GPI.

**Clean and Quiet Switching Option (+CQS)** – Provides automatic audio muting during switching transitions from one SDI input source to another to provide silence between input switches.

Audio LTC I/O (+LTC)

1RU Mounting Tray (supports 3 units) (BBG-1000-TRAY)

Redundant Power Supply Module (BBG-1000-PS)

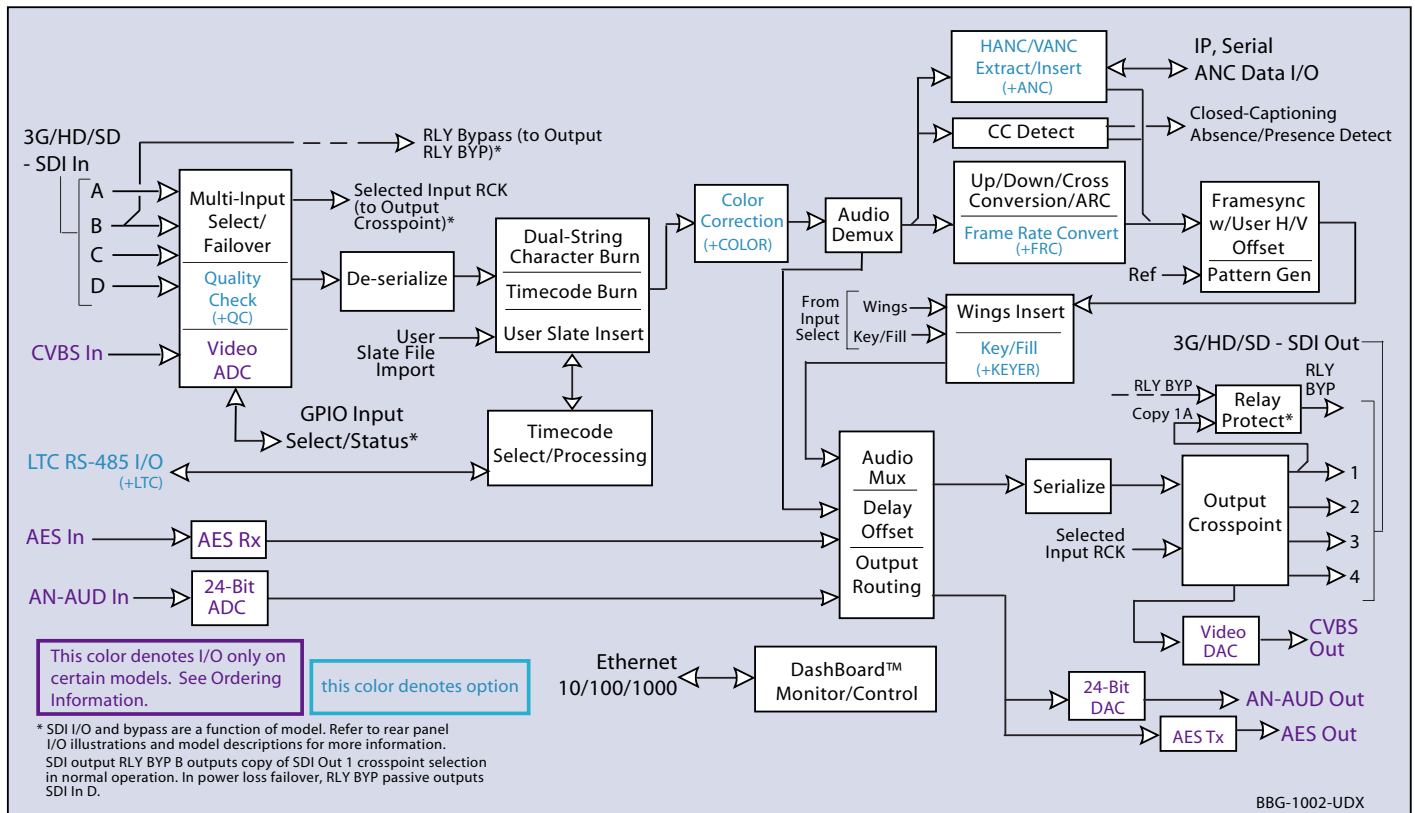

# BBG-1002-UDX • 3G/HD/SD-SDI Standalone Up-Down-Cross Converter/Frame Sync/ Audio Embed-De-Embed with Multi-Input Auto-Changeover

## SPECIFICATIONS

Note: Inputs/outputs are a function in some cases of model. See rear panel illustrations for I/O complements offered.

### Power

< 18 Watts. Power supplied by 12VDC AC adapter, universal input (included).

### SDI Input/Outputs

Up to (4) 75Ω BNC inputs  
 Up to (4) 75Ω BNC outputs (selectable as processed SDI IN or IN RCK)  
 SDI Formats Supported: SMPTE 259M, SMPTE 292M, SMPTE 424M  
 SDI Receive Cable Length: 3G/HD/SD: 120/180/320 m (Belden 1694A)  
 SDI Return Loss: >15 dB up to 1.485 GHz; >10 dB up to 2.970 GHz  
 SDI Alignment Jitter: 3G/HD/SD: < 0.3/0.2/0.2 UI  
 Minimum Latency (scaler and frame sync disabled): SD: 127 pixels (9.4 us); 720p: 330 pixels (4.45 us); 1080i: 271 pixels (3.65 us); 1080p: 361 pixels (2.43 us)

### CVBS Video Input/Outputs

(1) 75Ω BNC input  
 (1) 75Ω BNC output. CVBS can be upconverted to any supported SDI format; all formats can be downconverted to CVBS.  
 ADC resolution/sampling: 10-bit; 4x oversampling  
 DAC resolution/sampling: 10-bit; 16x oversampling  
 Y/C separation: 4 line Adaptive Comb Filter  
 Freq. Response: ± 0.25 dB to 5.5 MHz  
 SNR: > 50 dB to 5.5 MHz (unweighted)  
 Differential Phase: < 1 degree  
 Differential Gain: < 1%  
 Nonlinearity < 1%

### Discrete Audio Input/Outputs

(1) AES-3id 75Ω BNC input  
 (1) AES-3id 75Ω BNC output  
 (2) Balanced analog audio inputs  
 (2) Balanced analog audio outputs  
 I/O conforms to 0 dBFS = +24 dBu

### Input Select/Auto-Changeover Failover

Manual selection (forced) of any input.  
 · Failover to alternate input on loss of target input. Failover invoked upon LOS and/or (with option +QC) user configurable parametric criteria such as black/frozen frame or audio silence.  
 - Black frame trigger configurable for black intensity threshold and persistence time.  
 - Frozen frame trigger configurable for frozen percentage difference and persistence time.  
 - Audio silence trigger configurable for dBFS floor threshold and persistence time.  
 · Relay bypass SDI IN B to RLY BYP B upon loss of power.

### Frame Sync Audio/Video Delay

Max offset: 20 frames  
 Latency (min): 1 frame  
 Option +DLY Delay (3G/HD/SD): >800 msec / >1580 msec / >9000 msec

### ARC

ARC manually configurable (custom) or automatic triggering in full compliance/conformity with AFD (SMPTE 2016), VI (RP186), and WSS triggering.

### User Audio Delay Offset from Video

Bulk delay control: -33 msec to +3000 msec.  
 Per-channel delay controls: -800 msec to +800 msec

### Timecode Insertion/Burn-In

Burn-in and embedded video output timecode selected via user controls from input video SMPTE embedded timecode and/or audio LTC. Burn-in enable/disable user controls. Configurable for burn-in string of seconds, seconds:frames, seconds:frames:field. User controls for text size and H/V position.

### Text Burn-In

(2) independent strings supported. Independent insertions controls for enable/disable and enable upon LOS. User controls for text size and H/V position.

### GPIO/COMM

(2) GPI configurable to select input routing. (2) GPO configurable to invoke upon input selected. RS-232/485 comm port. All connections via rear module RJ-45 GPIO/COMM jack.

### Control/Monitor Interface

Front panel network setup. DashBoard remote control via 10/100/1000 Ethernet port.

### Frame Reference Input

Looping 2-BNC connection. SMPTE 170M/318M "Black Burst", SMPTE 274M/296M "Tri-Level". Return Loss: >35 dB up to 5.75 MHz

### Physical

Dimensions (WxHxD): 5.7 x 1.4 x 14.7 in (14.5 x 3.5 x 37.3 cm) Dimensions include connector projections. Weight: 6 lb (2.8 kg)

# BBG-1002-UDX • 3G/HD/SD-SDI Standalone Up-Down-Cross Converter/Frame Sync/ Audio Embed-De-Embed with Multi-Input Auto-Changeover

## ORDERING INFORMATION

**BBG-1002-UDX** 3G/HD/SD-SDI Stand-alone Up/Down/Cross Converting Frame Sync and Embedded Audio Proc with (4) 3G/HD/SD-SDI Input BNCs w/ (1) Relay Protect, (4) 3G/HD/SDI Output BNCs, GPIO/COMM (RJ-45 connector), (1) Gigabit Ethernet, Looping Reference and Redundant DC Power Inputs (includes one BBG-1000-PS Power Supply)

**BBG-1002-UDX-B** 3G/HD/SD-SDI Stand-alone Up/Down/Cross Converting Frame Sync and Audio Embedder/De-Embedder with (1) 3G/HD/SD-SDI Input BNC, (1) CVBS Input BNC, (1) AES Input BNC, (2) Balanced Analog Inputs, (1) 3G/HD/SDI Output BNC, (1) CVBS Output BNC, (1) AES Output BNC, (2) Balanced Analog Audio Outputs, (1) Gigabit Ethernet, Looping Reference I/O and Redundant DC Power Inputs (includes one BBG-1000-PS Power Supply)

**BBG-1002-UDX-C** 3G/HD/SD-SDI Stand-alone Up/Down/Cross Converting Frame Sync and Audio Embedder/De-Embedder with (1) 3G/HD/SD-SDI Input BNC, (1) CVBS Video In BNC, (2) AES In BNCs, (2) Balanced Analog Audio Inputs, (1) 3G/HD/SDI Output BNC, (1) CVBS Video Out BNC, (2) AES Out BNCs, (2) Balanced Analog Audio Outputs, (1) Gigabit Ethernet, Looping Reference I/O and Redundant DC Power Inputs (includes one BBG-1000-PS Power Supply)

**BBG-1002-UDX-D-DIN** 3G/HD/SD-SDI Stand-alone Up/Down/Cross Converting Frame Sync and Audio Embedder/De-Embedder with (4) 3G/HD/SD-SDI Inputs, (2) Balanced Analog Audio In, (6) AES Inputs, (4) 3G/HD/SDI Outputs w/ (1) relay protect, (4) AES Outputs, GPIO/COMM (RJ-45 connector) (1) Gigabit Ethernet, Looping Reference and Redundant DC Power Inputs (includes one BBG-1000-PS Power Supply; All coaxial connectors DIN 1.0/2.3)

**BBG-1002-UDX-D-HDBNC** 3G/HD/SD-SDI Stand-alone Up/Down/Cross Converting Frame Sync and Audio Embedder/De-Embedder with (4) 3G/HD/SD-SDI Inputs, (2) Balanced Analog Audio In, (6) AES Inputs, (4) 3G/HD/SDI Outputs w/ (1) relay protect, (4) AES Outputs, GPIO/COMM (RJ-45 connector) (1) Gigabit Ethernet, Looping Reference and Redundant DC Power Inputs (includes one BBG-1000-PS Power Supply; all coaxial connectors HDBNC)

### Options and Accessories:

**+ANC** Ancillary Data Processor Option

**+COLOR** Color Correction Option

**+KEYER** Key/Fill Keyer Option

**+FRC** Linear Frame Rate Conversion Option

**+LTC** Audio LTC I/O Option

**+QC** Quality Check Option

**+CQS** Clean and Quiet Switching Option

**+TTS** Text-To-Speech Option (Acapela Text-To-Speech from Acapela Group™. Fielded units must be returned to Cobalt for installation of speech library SD memory card onto host unit as well as software upload. Please contact Support for more information.)

**+2L-SPAN** Add Spanish-language upgrade (add-on to option +TTS; option +TTS required)

**+EAS** Emergency Alert System Text Crawl Generation Option

**+T-SLATE** User Trouble Slate Graphic Import Option

**+LOGO** Logo Insertion Option

**+DLY** Extended Frame Sync Delay Option

**+SCTE104** SCTE 104 Insertion Option

**+SCTE104-FAST** Frame-Accurate SCTE 104 Trigger Insertion Option

**BBG-1000-PS** Redundant Power Supply Module

**BBG-1000-TRAY** 1RU Mounting Tray (supports 3 units)

**BBG-1002-UDX • 3G/HD/SD-SDI Standalone Up-Down-Cross Converter/Frame Sync/  
Audio Embed-De-Embed with Multi-Input Auto-Changeover**

**Rear Panel**

