

BBG-1022-FS-DSP • 3G/HD/SD-SDI Standalone Frame Sync with Audio/Video Processing, DSP Audio Support, Audio Embed/De-Embed and CVBS I/O



The Cobalt® **BBG-1022-FS-DSP 3G/HD/SD-SDI Standalone Frame Sync with Audio/Video Processing, DSP Audio Support, Audio Embed/De-Embed and CVBS I/O** offers frame sync, and advanced audio and ancillary data support, plus many other powerful features. The 9922-FS-DSP offers a DSP-based platform that supports multiple audio DSP options. When optioned with various audio processing options, the DSP-based processing core (which supports numerous simultaneous processing engines) uses license “credits” which allows flexible tailoring of multiple proc function instances. The 9922-FS-DSP provides much more flexibility than other audio processors that used fixed processing assets (for example, this flexibility allows “trading” credits for more Dolby encoders while backing out of loudness processors or other engine assets).

Option **+TTS** provides high-quality Text-To-Speech synthesis, directly converting EAS text to digital audio speech with no baseband signal breakouts or add-ons. Advanced frame sync features include per-channel audio delay, audio/video offset, and output rate conversion to and from 23.98/29.97/59.94 to 24/30/60 frame rates.

A convenient input crosspoint with RP168 clean switching can select from up to four SDI inputs. The input crosspoint allows manual selection of input via remote control or GPIO, or failover to alternate inputs on loss of input conditions. Two discrete character burn strings can be inserted on output video, with each string inserted as static text and/or insert only upon LOS. With option **+T-SLATE**, import of user trouble slate graphics is also supported in addition to standard test pattern insert as an input LOS/quality event marker. A moving-box insertion can serve as a dynamic raster confidence check even when the input video image is static. Included standard is closed captioning absence/presence detection for CEA 608/708 and line 21 SD closed captioning. Quality Check option **+QC** checks for and acts upon user-configurable criteria such as black/frozen frame, audio silence or CC absence.

Preset save/load allows saving custom settings while allowing one-button revert to factory settings. Layered presets allow invoking changes related only to a specific area of concern (audio routing, for example) while not changing any other processing settings or aspects. The BBG-1022-FS-DSP can be remote-controlled using DashBoard™. The compact standalone form factor allows desktop usage, as well as the 1/3-rack size of the BBG-1022-FS-DSP allowing 3 units to be installed in a 1RU space (an optional mounting tray is available that provides secure mounting of the units to a standard 19” frame).

FEATURES

DSP-based platform supports multiple audio DSP options, with multiple instances available using allocatable license “credits” – our largest DSP capacity

Dolby encoding/decoding, loudness processing, and upmixing DSP audio options available. Auto Adjust feature helps assure lip sync by assessing and alerting where DSP processing requires matching video delay.

Full audio crosspoint with 5.1-to-stereo downmix (standard) available for all audio outputs

CVBS analog video I/O and analog/AES embed / de-embed available

Moving-box/motion insertion enable serves as a dynamic raster confidence check even in cases where the input video image is static.

Compact footprint – up to 3 units in a 1RU space. Optional tray provides secure captive-fastener mounting of 3 units in a 1RU tray.

Supports all popular formats: 480i, 576i, 720p, 1080i, 1080pSF, 1080p

Uses DashBoard remote control (device appears as single-card frame)

OPTIONS

Dolby® Real-Time Loudness Leveling Automatic Loudness Processing Options (**+DSP-RTLL**) – Provides advanced loudness processing with comprehensive parametric controls. Available as surround 5.1 and stereo 2.0. (See Ordering Information for full details)

Dolby® Encoder Options (**+DSP-ENCD**) – Available as 5.1 and 2.0 Dolby Digital/Digital Plus Encode. (See Ordering Information for full details.)

Dolby® Decoder Options (**+DSP-DEC**) – Provides Dolby Digital, Digital Plus, and E decode

Linear Acoustic® UPMAX™ Upmixing (**+DSP-UPMIX-LA**) – Provides automatic 2.0-to-5.1 Linear Acoustic® UPMAX™ upmixing

Linear Acoustic® AEROMAX™ Loudness Processor Options (**+DSP-LP**) – Available as surround 5.1 and stereo 2.0. (See Ordering Information for full details.)

Audyne ITU Loudness Leveler Options (**+DSP-ITU**) – Available as surround 5.1 and stereo 2.0. (See Ordering Information for full details.)

Quality Check Option (**+QC**) – Provides failover, alert, or user presets action on criteria such as black/frozen frame, audio silence, and CC absence

Clean & Quiet Switching Option (**+CQS**) – Provides automatic audio ramp-down and up during input switching events

Text-To-Speech Option (**+TTS**) – Provides Text-To-Speech synthesis, directly converting EAS text to digital audio speech with no baseband signal breakouts or add-ons. High-quality Text-To-Speech from Acapela Group.

Add Extended Delay Option (**+DLY**)

Color Correction (**+COLOR**) – Full RGB color corrector (offset, gain, gamma) with extended YCbCr proc controls with white/black hard clip, white soft clip, and saturation clip

Trouble Slate Import (**+T-SLATE**) – Allows uploading of up to three different user trouble slate graphic file to card, with automated insertion controlled by GPI or other events

Logo Insertion (**+LOGO**) – Allows uploading of user logo graphic file to card, with automated insertion controlled by GPI or other events

Ancillary Data Processor Option (**+ANC**) – Provides full user VANC/HANC packet insertion/extraction access to DID/SDID ancillary data, with insert/extract to and from IP and GPIO external interfaces

SCTE104 Frame-Accurate SCTE Trigger Insertion Option (**+SCTE104-FAST**) Provides deterministic, frame-accurate Digital Program Insertion (DPI) message embedding into SDI, optimizing it for automatic dissemination to CDN and VOD systems

Audio LTC I/O Option (**+LTC**)

1RU Mounting Tray (supports 3 units) (**BBG-1000-TRAY**)

Redundant Power Supply Module (**BBG-1000-PS**)

BBG-1022-FS-DSP • 3G/HD/SD-SDI Standalone Frame Sync with Audio/Video Processing, DSP Audio Support, Audio Embed/De-Embed and CVBS I/O

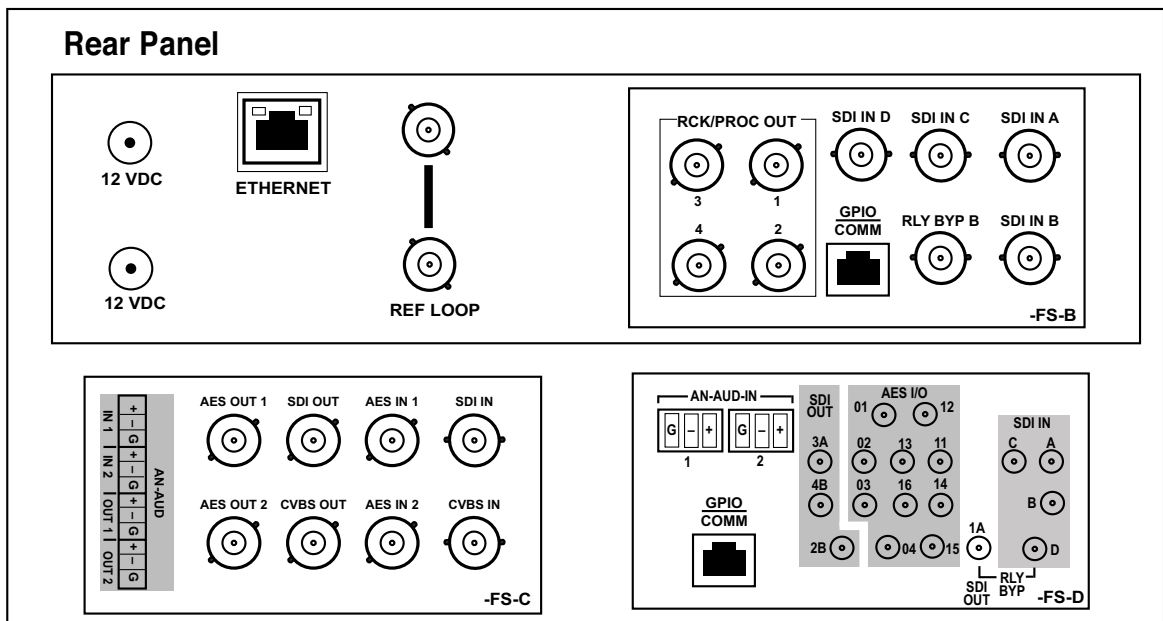
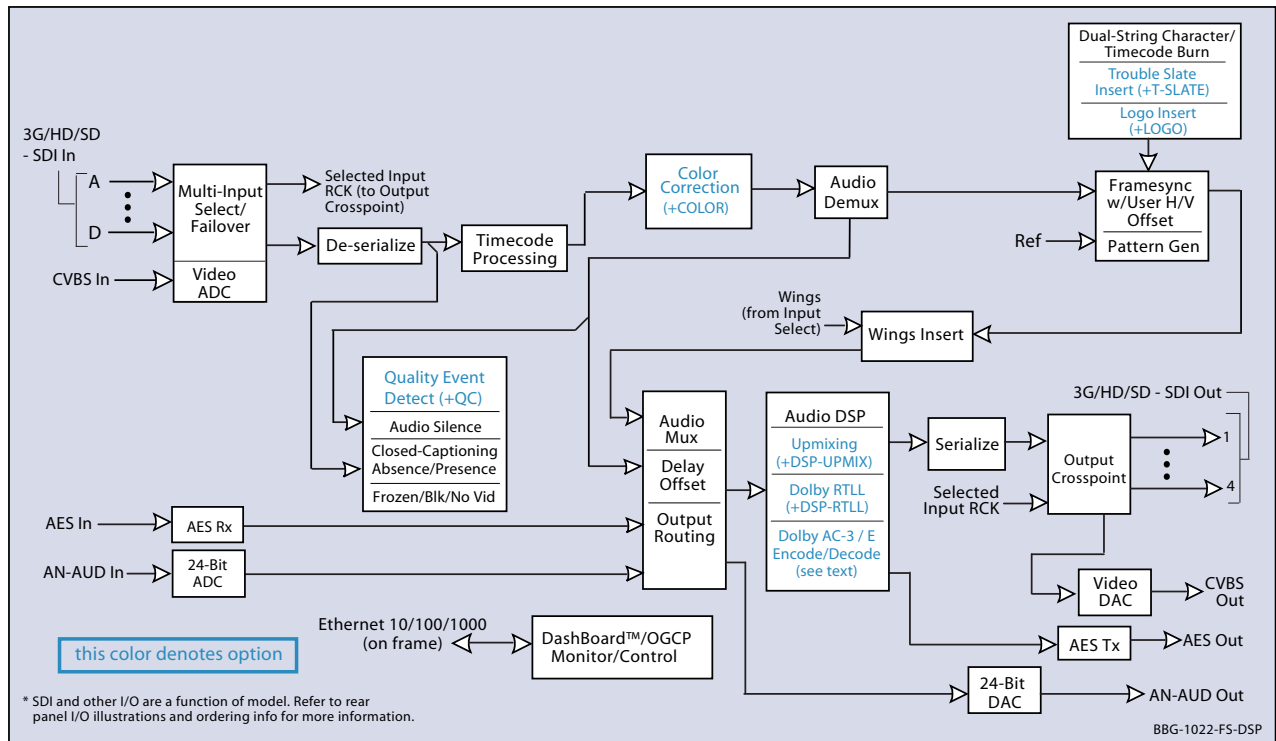

BBG-1022-FS-DSP • 3G/HD/SD-SDI Standalone Frame Sync with Audio/Video Processing, DSP Audio Support, Audio Embed/De-Embed and CVBS I/O

SPECIFICATIONS

Power

< 24 Watts (including DSP options). Power supplied by 12VDC AC adapter, universal input (included).

SDI Input/Outputs

Up to (4) 75Ω BNC inputs
 Up to (4) 75Ω BNC outputs (selectable as processed SDI IN or IN RCK)
 SDI Formats Supported: SMPTE 259M, SMPTE 292M, SMPTE 424M
 SDI Receive Cable Length: 3G/HD/SD: 120/180/320 m (Belden 1694A)
 SDI Return Loss: >15 dB up to 1.485 GHz; >10 dB up to 2.970 GHz
 SDI Alignment Jitter: 3G/HD/SD: < 0.3/0.2/0.2 UI
 Timing Jitter: 3G/HD/SD: < 2.0/1.0/0.2 UI
 Minimum Latency (frame sync disabled): SD: 127 pixels (9.4 us); 720p: 330 pixels (4.45 us); 1080i: 271 pixels (3.65 us); 1080p: 361 pixels (2.43 us)

CVBS Video Input/Outputs

(1) 75Ω BNC input
 (1) 75Ω BNC output. CVBS output functional only when selected path is carrying SD-SDI.
 ADC resolution: 9-bit
 Sampling frequency: 27 MHz (2x over-sampling)
 Y/C separation: 4 line Adaptive Comb Filter
 Freq. Response: ± 0.25 dB to 5.5 MHz
 SNR: > 50 dB to 5.5 MHz (unweighted)
 Differential Phase: < 1 degree
 Differential Gain: < 1%
 Nonlinearity < 1%

Discrete Audio Input/Outputs

AES-3id 75Ω inputs (8 pair (16-Ch) max) AES-3id 75Ω outputs (8 pair (16-Ch) max)
 Input AES SRC Range: 32 to 96 kHz
 Balanced analog audio inputs (4-Ch max)
 Balanced analog audio outputs (4-Ch max)
 (I/O conforms to 0 dBFS = +24 dBu)
 Analog Output Impedance: < 50 Ω
 Analog Reference Level: -20 dBFS
 Analog Nominal Level: +4 dBu
 Analog Max Output Level: +24 dBu (0 dBFS)
 Analog Freq. Response: ±0.2 dB (20 Hz to 20 kHz)
 Analog SNR: 115 dB (A weighted)
 Analog THD+N: -96 dB (20 Hz to 10 kHz)
 Analog Crosstalk: -106 dB (20 Hz to 20 kHz)

Frame Sync Audio/Video Delay

Max offset: 20 frames
 Latency (min): 1 frame
 Option +DLY Delay (3G/HD/SD): >800 msec / >1580 msec / >9000 msec

User Audio Delay Offset from Video

Bulk delay control: -33 msec to +3000 msec.
 Per-channel delay controls: -800 msec to +800 msec

Text Burn-In

(2) independent strings supported. Independent insertions controls for enable/disable and enable upon LOS. User controls for text size and H/V position.

GPIO/COMM

(2) GPI configurable to select input routing. (2) GPO configurable to invoke upon input selected. RS-232/485 comm port.

Control/Monitor Interface

Front panel network setup. DashBoard remote control via 10/100/1000 Ethernet port.

Frame Reference Input

Looping 2-BNC connection. SMPTE 170M/318M "Black Burst", SMPTE 274M/296M "Tri-Level"
 Return Loss: >35 dB up to 5.75 MHz

Physical

Dimensions (WxHxD): 5.7 x 1.4 x 14.7 in (14.5 x 3.5 x 37.3 cm) Dimensions include connector projections.
 Weight: 6 lb (2.8 kg)

BBG-1022-FS-DSP • 3G/HD/SD-SDI Standalone Frame Sync with Audio/Video Processing, DSP Audio Support, Audio Embed/De-Embed and CVBS I/O

ORDERING INFORMATION

BBG-1022-FS-DSP 3G/HD/SD-SDI Standalone Frame Sync with Audio/Video Processing, DSP Audio Support, Audio Embed/De-Embed and CVBS I/O available in the following rear-panel I/O configurations:

BBG-1022-FS-DSP-B (4) 3G/HD/SD-SDI Input BNCs, (4) 3G/HD/SD-SDI Output BNCs, (1) 3G/HD/SDI Output BNC (with relay bypass failover), (1) GPIO/COMM RJ-45 connector

BBG-1022-FS-DSP-C (1) 3G/HD/SD-SDI Input BNC, (1) CVBS Video In BNC, (2) AES In BNCs, (2) Balanced Analog Audio Inputs, (1) 3G/HD/SDI Output BNC, (1) CVBS Video Out BNC, (2) AES Out BNCs, (2) Balanced Analog Audio Outputs

BBG-1022-FS-DSP-D-DIN ((4) 3G/HD/SD-SDI Inputs, (2) Balanced Analog Audio In, (6) AES Inputs, (4) 3G/HD/SDI Outputs w/ (1) relay protect, (4) AES Outputs, GPIO/COMM (RJ-45 connector). (All coaxial connectors DIN 1.0/2.3)

BBG-1022-FS-DSP-D-HDBNC (4) 3G/HD/SD-SDI Inputs, (2) Balanced Analog Audio In, (6) AES Inputs, (4) 3G/HD/SDI Outputs w/ (1) relay protect, (4) AES Outputs, GPIO/COMM (RJ-45 connector). (All coaxial connectors HD-BNC)

Options and Accessories:

+DSP-RTL-5.1 Dolby® RTLL™ 5.1-Channel Loudness Processor Option

+DSP-RTL-2.0 Dolby® RTLL™ Stereo Loudness Processor Option

+DSP-ENCD-5.1 Dolby® Digital/Digital Plus 5.1 Encoder

+DSP-ENCD-2.0 Dolby® Digital/Digital Plus 2.0 Encoder

+DSP-DEC Dolby® Decoder

+DSP-UPMIX-LA Linear Acoustic® UPMAX™ 2.0-to-5.1 Upmixer

+DSP-LP-5.1 Linear Acoustic® AEROMAX™ 5.1-Channel Loudness Processor Option

+DSP-LP-2.0 Linear Acoustic® AEROMAX™ 2-Channel Loudness Processor Option

+DSP-ITU-5.1 Audyne ITU 5.1-Channel Loudness Leveler Option (1)

+DSP-ITU-2.0 Audyne ITU 2.0-Channel Loudness Leveler Option (1)

+ANC Ancillary Data Processor Option

+COLOR Color Correction Option

+T-SLATE User Trouble Slate Graphic Import Option

+LOGO Logo Insertion Option

+SCTE104 SCTE 104 Insertion Option

+SCTE104-FAST Frame-Accurate SCTE 104 Trigger Insertion Option

+DLY Extended Frame Sync Delay Option

+LTC Audio LTC I/O Option

+CQS Clean & Quiet Switching Option

+QC Quality Check Option

+TTS Text-To-Speech Option (Acapela Text-To-Speech from Acapela Group™. Installation requires option upload and installation of speech library SD memory card onto host card. Pre-loaded SD card and instructions provided.)

+2L-SPAN Add Spanish-language upgrade (add-on to option +TTS; option +TTS required)

BBG-1000-PS Redundant Power Supply Module

BBG-1000-TRAY 1RU Mounting Tray (supports 3 units)

(1) Manufactured under license from Audyne Inc.