

**BBG-IP-TO-SDI-10GE-2110 • SMPTE ST 2110 To 3G/HD/SD-SDI De-Encapsulator with SDI, HDMI, and Stereo Analog Audio Monitoring Outputs**

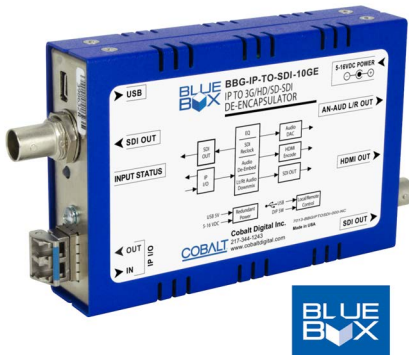

The Blue Box **BBG-IP-TO-SDI-10GE-2110** SMPTE ST 2110 To 3G/HD/SD-SDI De-Encapsulator with SDI, HDMI, and Stereo Analog Audio Monitoring Outputs is a part of the Blue Box Group™ of compact, rugged, and portable converter boxes. BBG-IP-TO-SDI-10GE-2110 offers a compact throwdown unit that provides the flexibility of IP-to-SDI de-encapsulation as well as providing an HDMI output, two reclocked SDI coax outputs, and a convenience analog stereo de-embed monitor pair with built-in Lt/Rt downmixer. The 10GigE host connection can be used directly with 10GigE video switches and routers. BBG-IP-TO-SDI-10GE-2110 supports 2110 video (part 20), audio (part 30), and ancillary data (part 40) as well as timing (part 21).

BBG-IP-TO-SDI-10GE-2110 can be configured using the device DIP switches or by using an intuitive GUI application that communicates with BBG-IP-TO-SDI-10GE-2110 over a PC's USB port. The GUI app allows dynamic configuration control, status display, and other advanced control functions not commonly found on "throwdown" packages. When configured using the GUI app, the USB connection can be removed with all settings held in non-volatile device memory.

**FEATURES**

ST 2110, ST 424, ST 292, and ST 259 compliant

Powers directly from host equipment USB or standard corded power adapter. USB power and corded adapter can be simultaneously used to provide redundant power sourcing.

Stereo analog audio monitoring output with Lt/Rt downmixer

Configurable using device DIP switches or USB GUI remote control offering dynamic configuration control, status display, and other advanced control functions not commonly found on "throwdown" packages

Compact size and low weight design easily affixes directly to camera or host device chassis

Rugged construction backed with a five-year warranty

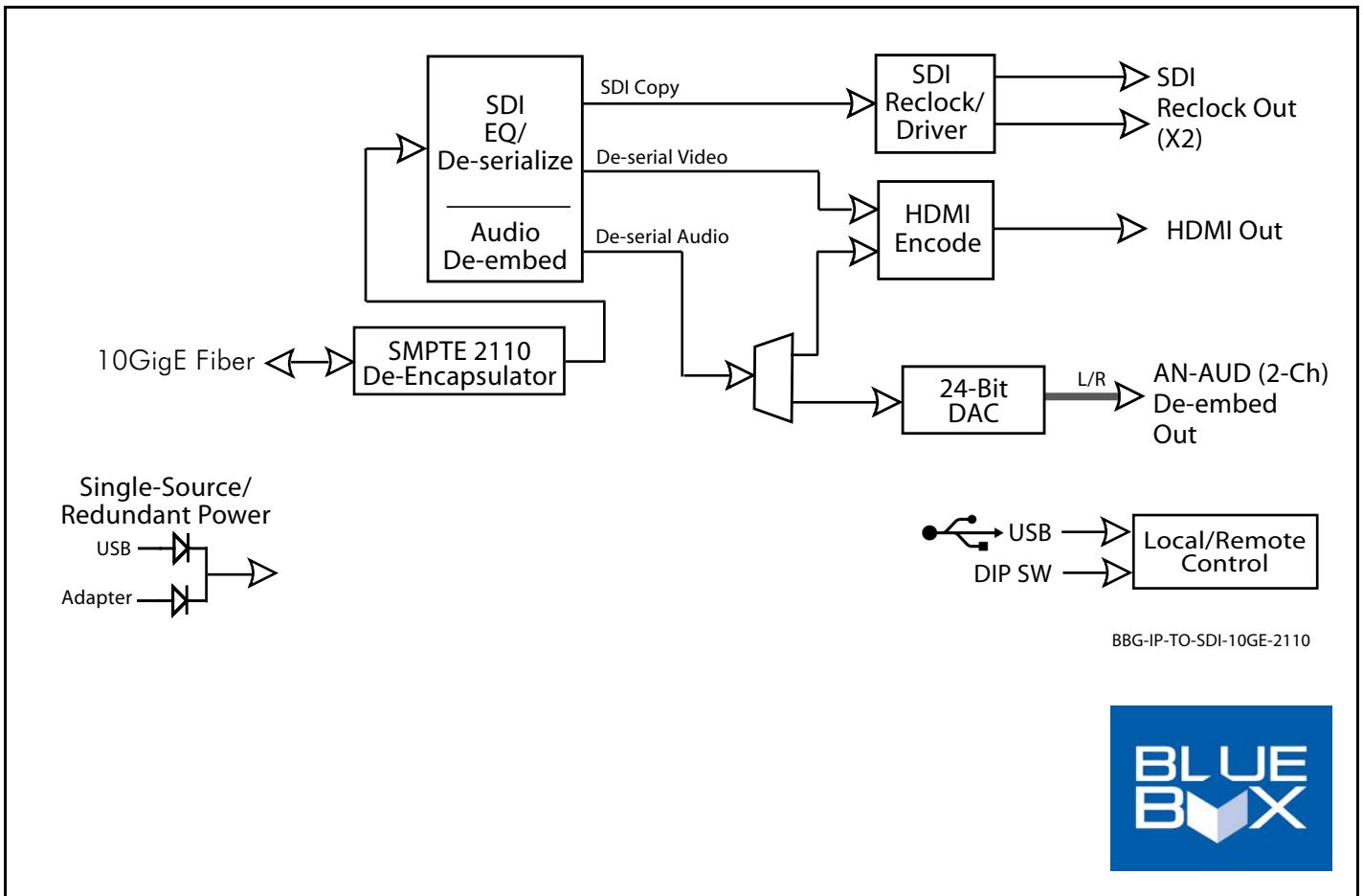

**BBG-IP-TO-SDI-10GE-2110 • SMPTE ST 2110 To 3G/HD/SD-SDI De-Encapsulator**  
with SDI, HDMI, and Stereo Analog Audio Monitoring Outputs**SPECIFICATIONS****Standards Supported**

SMPTE 259M, 292M, 424M, ST 2110, ST 424, ST 292, and ST 259

**Inputs/Outputs**

(1) 10GigE Fiber I/O; Multi-Mode; LC connectors  
(2) 3G/HD/SD-SDI 75Ω BNC outputs  
Fiber Wavelength, Tx: 1310 nm  
Tx Power: -5.0 dBm (min)  
(1) HDMI output (HDMI 1.4a compliant). HDMI output can be set as DVI-D (limited to SMPTE HD formats).  
(1) Stereo analog audio out (L/R unbalanced pair via 3.5mm TRS jack)  
SDI Formats Supported: SMPTE 259M, SMPTE 292M, SMPTE 424M

**Audio Conversion Format**

48 kHz sampling, 24-bit  
8-Ch HDMI from SDI groups 1 and 2

**Power Source**

Power-sourced directly from host equipment USB port. Converter can also be powered using corded AC adapter (included)

**Power**

5-16 VDC, 5W

**DC Power Connectors**

USB Mini and coaxial locking connector (for use with supplied Cobalt power adapter)

**USB Port**

Mini-USB (used for power source, USB remote control connection, and firmware upgrade upload to device)

**Dimensions (WxHxD)**

5.5" x 3" x 1" (including connector projections)  
(139 x 77 x 26 mm)

**Operating Temperature Range**

32°F to 95°F  
(0°C to 35°C)

**ORDERING INFORMATION**

**BBG-IP-TO-SDI-10GE-2110** SMPTE ST 2110 To 3G/HD/SD-SDI De-Encapsulator with SDI, HDMI, and Stereo Analog Audio Monitoring Outputs

**BBG-MB** Mounting Bracket (see Product Downloads for downloading installation instruction sheet)

**Note:** The USB GUI application available for BBG-IP-TO-SDI-10GE is a free download (Windows Security Certified) that can be downloaded from our Support web page. Instructions for downloading and using the app are included in product documentation. The application is not required for device usage where only DIP switch configuration is desired.

Currently, this application is available for only the following operating systems:

- Windows Vista
- Windows 7
- Windows 8
- Windows 8.1
- Windows 10